

USE OF OVERHEAD IRRIGATION LINES TO APPLY LIQUID FERTILIZERS AND
WEEDICIDES TO NURSERY BEDS

Karl Lanquist

Nurseryman, Mt. Shasta Nursery, U.S. F. S.
McCloud, California

The purpose of the following description and drawing is to explain how to apply liquid chemicals (fungicides, fertilizers, etc.) to nursery beds by injecting them directly into the overhead sprinkling lines. A venturi tube temporarily set into the overhead line makes such a practice simple and cheap. A tube of this kind is inexpensive and when set in the line and connected with hoses to a suitable tank of the chemical, it does its job automatically merely by the force of the irrigating water flowing normally through the lines. No outside source of power, pumps, or other moving parts are required.

At Shasta Nursery the device is used to apply allyl alcohol weed killer, but the device will work equally well with liquid fertilizers, fungicides, or other chemicals.

(Editor's note: The use of allyl alcohol as a weed killer has been discussed in other articles and is not repeated here. See Tree Planters' Notes Numbers 7 and 12, and the June 1952 Journal of Forestry, Volume 50, Number 6, page 470 for articles about allyl alcohol.)

The installation and operation of the venturi is as follows:

- (a) Load supply of chemical and the empty mixture tank on a vehicle and position it close to riser.
- (b) Disconnect overhead line from ell at top of the riser and install the venturi horizontally in the overhead line by means of unions, or nipple and union.
- (c) Connect venturi to mixture tank with two hoses. Close valve D, open valve C, and remove filler cap A. Turn on overhead line (open valve B). Mixture tank will fill with water to any desired level while overhead lines are operating. Shut off overhead lines when desired quantity of water is in mixture tank. (If using allyl alcohol be sure to do this before putting in alcohol.)

(d) If using allyl alcohol put on gas mask. Submerge in the mixture tank the hose from pump of the alcohol supply barrel and pump in desired amount of alcohol. (This under-water transfer of the alcohol is important for in this way this dangerous material is never exposed to the air, a vital safety precaution.) Remove hose and replace filler cap A.

(e) Close valves D and C and turn on overhead line (open valve B.) Operate overhead line for a minute or two.

(f) Open valves C and D. Water flowing in the overhead line through the venturi will automatically suck the mixture from the tank and mix it into the irrigation water to be sprayed over the beds from entire length of line. About 30 minutes is required to inject 40 gallons of mixture.

(g) Closing valve C will stop discharge from mixture tank at any time without affecting flow of water through overhead line.

We bought our venturi from the Dragon Engineering Company, Oakland, California. The venturi and a 40-gallon mixture tank capable of withstanding 50 p. s. i. pressure cost about \$160. I do not know the current cost of the venturi alone, but since the principle involved is very old there is nothing patentable in this device and no doubt one could be made from aluminum, brass, or steel by any good local machinist for less than it cost us. The hoses should be of clear plastic to permit observation of flow.

The installation and removal of the venturi would be simplified if the overhead line were connected to the riser with a union instead of a nipple. Then it would be a simple matter to uncouple the union and install the venturi by unions at each end. This, of course, would require the permanent installation of a union at each riser. Unions cost us about \$2.00 apiece; hence to save expense we used but one union, plus the nipple already in place.

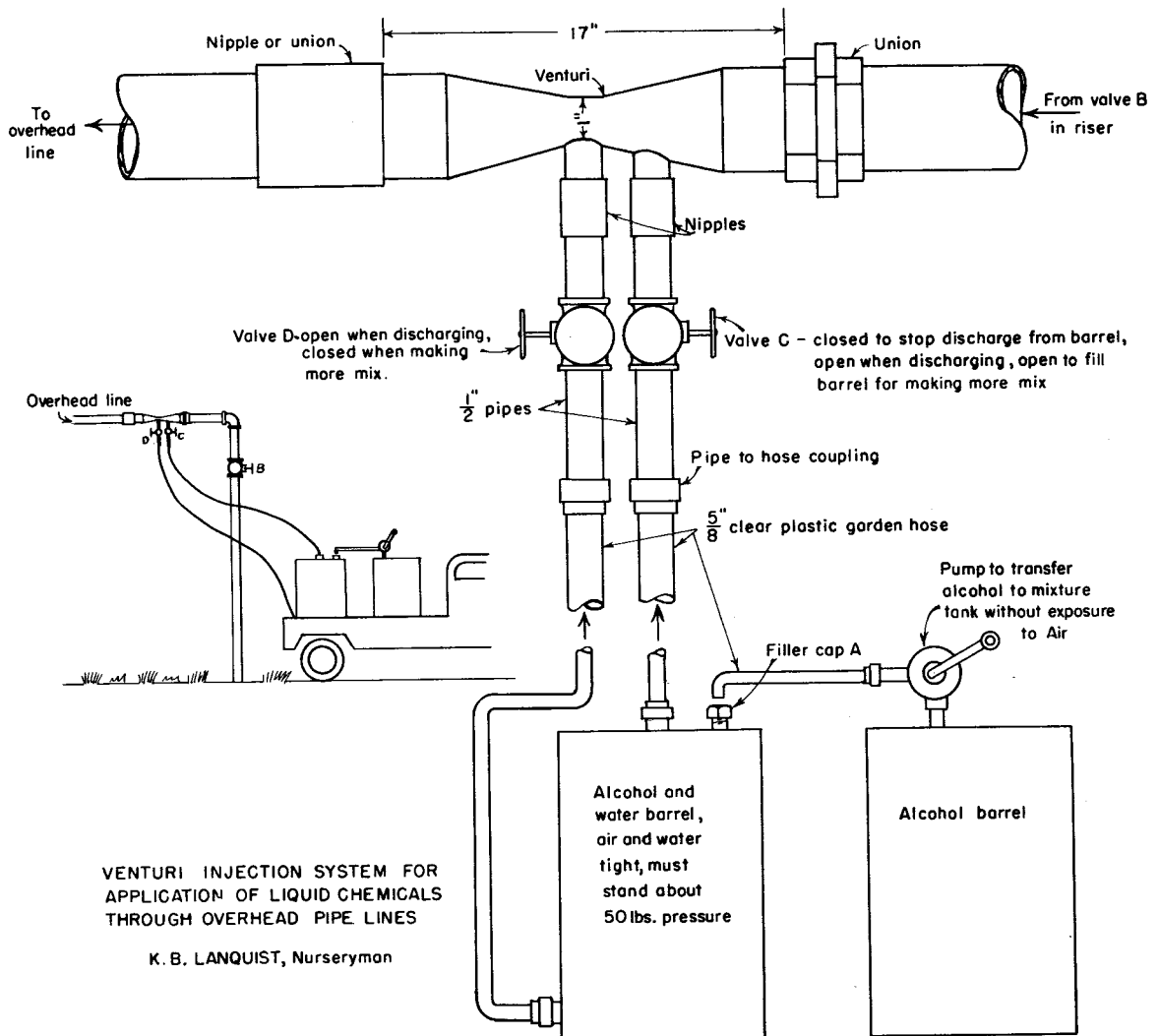

SEEDLING HARVESTER

Karl B. Lanquist

Nurseryman, Mt. Shasta Nursery, U. S. Forest Service Mc Cloud,
California

To speed tree digging at Shasta Nursery, we have developed the machine shown below.- After digging two adjacent beds in the usual manner, the harvester passes over them and the trees are pulled by a crew of 4 or 5 pickers and 1 or 2 packer-trimmers riding on the machine. The pickers pull the seedlings, grade them, count them (25 or 50 to the bunch) and place them on the conveyor belt which carries them to the packers. The packers take them from the trough into which they fall from the belt, prune the roots, tie the bunch and put it into a box for removal periodically to the packing shed or heeling in beds.

The harvester can be adapted to almost any condition--to large--or small-scale operations. It has been used successfully on 5 beds at a time with 2 pickers assigned to each bed walking behind the machine, and the same crew of packers. When the machine is used in this way, the seats are unnecessary. Obviously the Harvester would be lighter, more maneuverable, and somewhat less expensive to manufacture if it did not provide for carrying the pickers.

The "Seedling Harvester" has greatly improved the quality and quantity of production at this nursery.

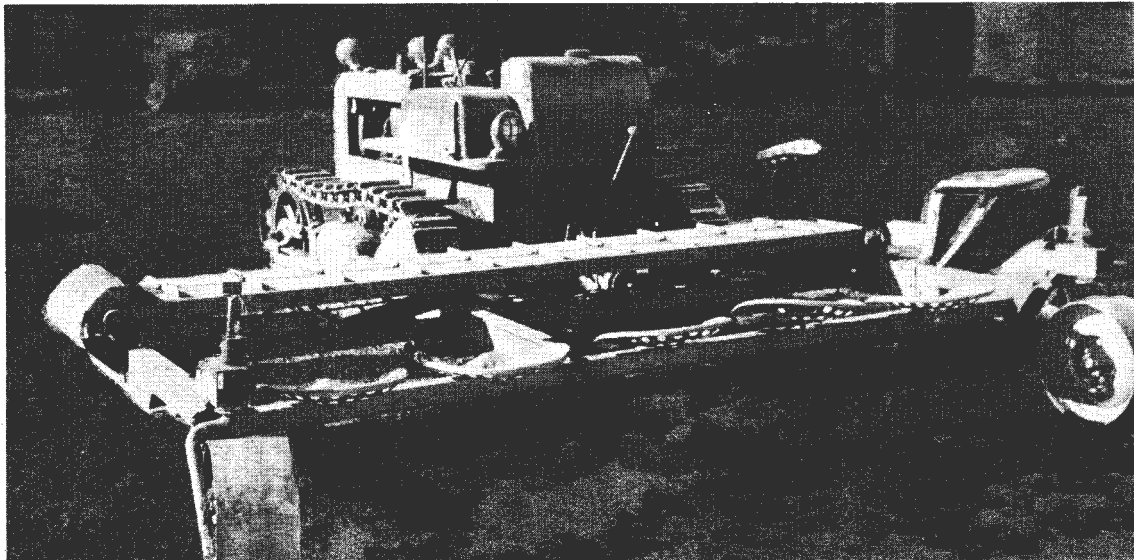

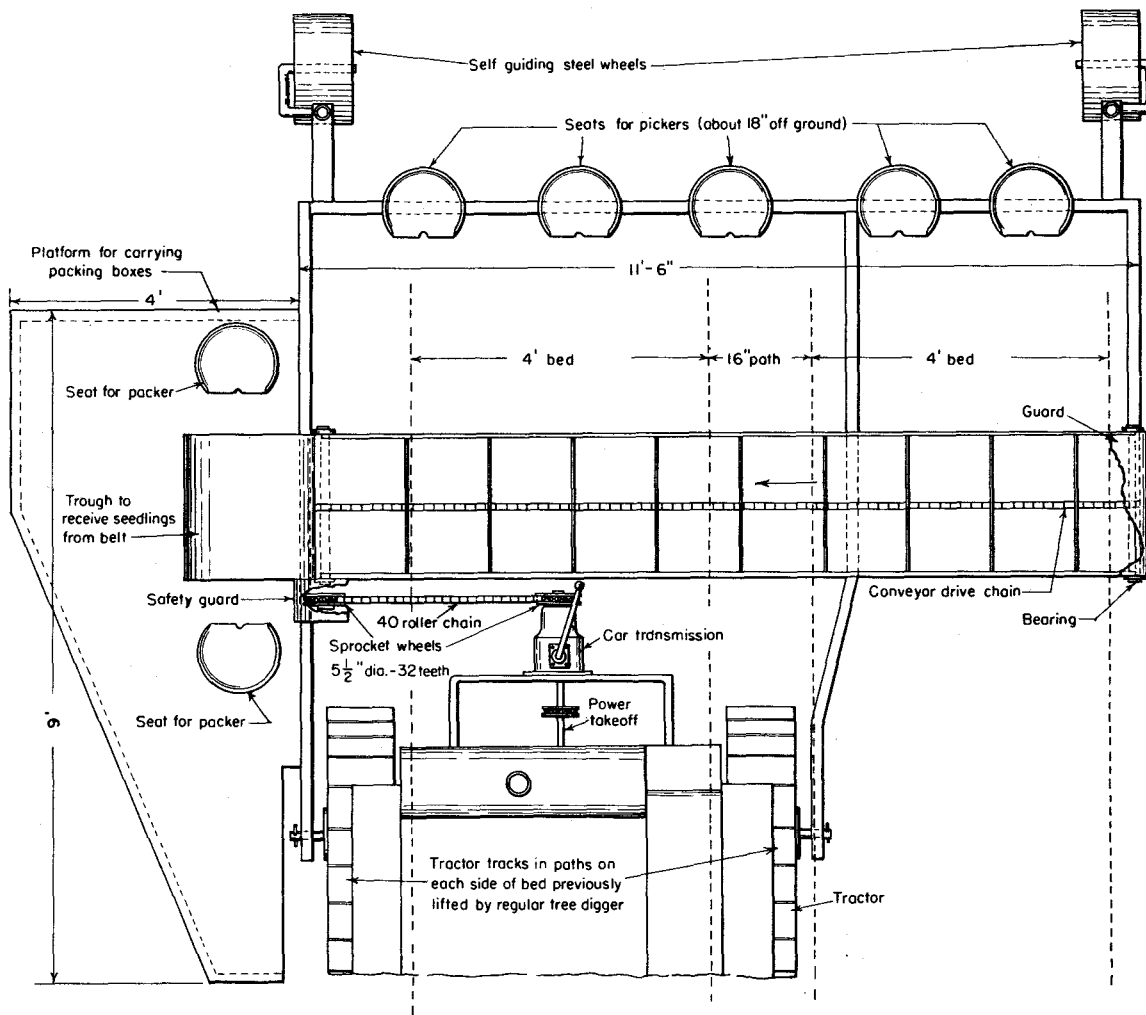

SEEDLING HARVESTER
 DESIGNED BY FLOYD BEALL AND KARL B. LANDQUIST
 MT. SHASTA NURSERY
 U.S. FOREST SERVICE

Drawn U.S.F.S., W.O. 1953

METHOD OF UNLOADING STRAW FROM A TRUCK

William O. Garlington

Forestry Aid, Kisatchee National Forest
Alexandria, Louisiana

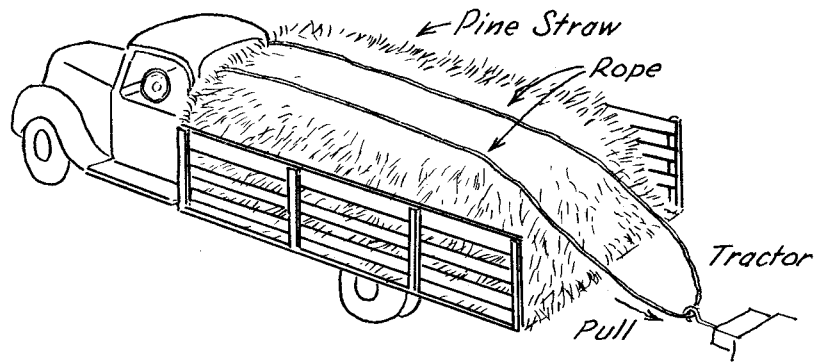
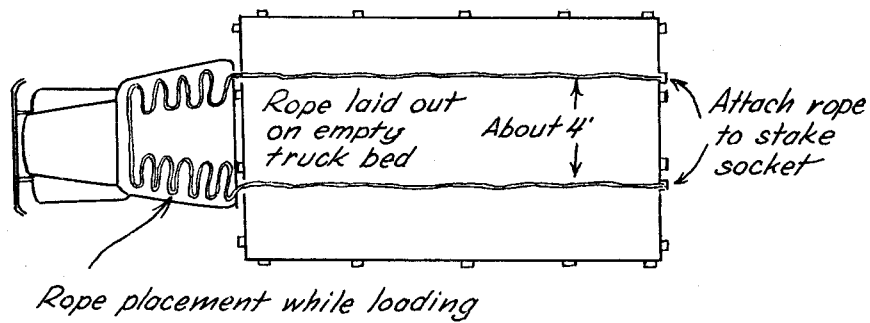

The two ends of a thirty-foot piece of one-inch rope are fastened to two stake sockets at the rear of the truck bed. The rope is laid along the bed of the truck with the two strands about four feet apart. The surplus rope is placed on the truck cab.

Pine straw is loaded on the rope in the truck bed and when the load is completed the remainder of the rope is brought over the top of the load with the loop hanging down the back of the load.

At the unloading point, a chain is hooked into the rope loop and a tractor is used to pull the load out of the truck.

OHIO NURSERY DEVELOPS SIX-ROW TRANSPLANTER

Irving Dickman
Assistant Chief, Division of Forestry Ohio
Department of Natural Resources
Columbus 15, Ohio

In the July 1949 issue of the Journal Of Forestry, there appeared on page 531 an article entitled "The New Bradley Transplanter." The article pertained to a seedling transplanter that was developed by Tom O. Bradley, Nursery Manager, Soil Conservation Service Nursery, Zanesville, Ohio. This transplanter differs from the usual type found in forest tree nurseries in that it plants five rows instead of the normal two rows in one operation.

In some nurseries, the transplant bed consists of six rows, and when this bed is reduced to five rows, it requires an additional twenty percent of land area to transplant the same number of trees. Having noted the success of the five-row transplanter at Zanesville, the staff at the Marietta Nursery, Ohio Division of Forestry, Marietta, Ohio, started work on a six-row transplanter.

After much planning, and with the able assistance of Mr. Tom Bradley and two commercial machine shops, the six-row transplanter was developed and placed in service at the Marietta Nursery in September 1949. A Cletrac Model E tractor was modified so as to pull the transplanter at a speed of only 10 feet a minute. The bulk of the fall transplanting was done with this machine, and it has been used for practically all planting in 1950. To date, it has averaged transplanting about 100,000 trees daily, and the Marietta staff is quite enthusiastic about this piece of equipment.

Blueprints showing detailed plans of this transplanter can be obtained at a cost of \$1.00 per set from The Department Of Natural Resources, Division of Forestry, 1500 Dublin Rd., Columbus 12, Ohio.

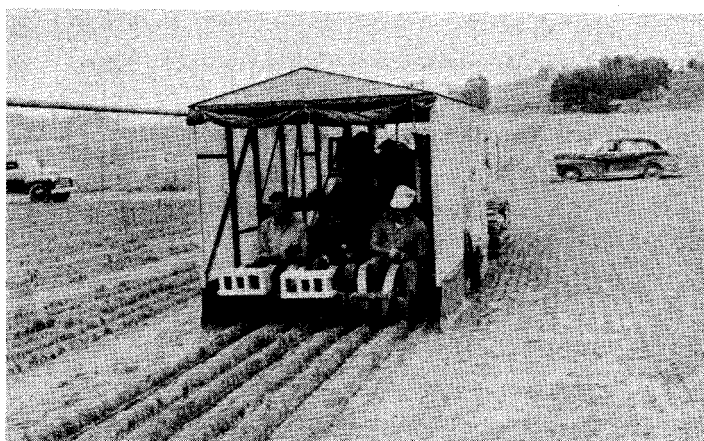

MODIFICATIONS OF A HOLLAND TRANSPLANT MACHINE

Karl B. Lanquist
Nurseryman, Mt. Shasta Nursery, U. S. F. S.
McCloud, California

The Holland transplant machines used at this nursery sometimes caused the trees to be planted with roots in an L-shape. Modifications made to these machines, as shown in the following drawings, did away with this difficulty.

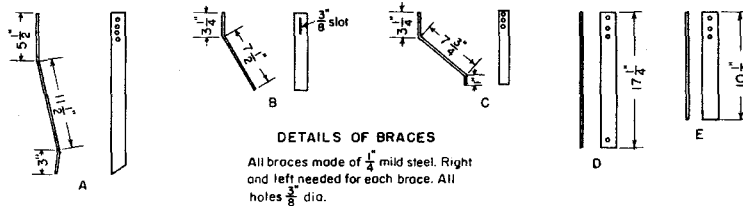
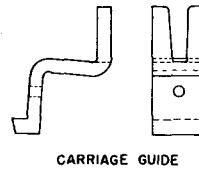
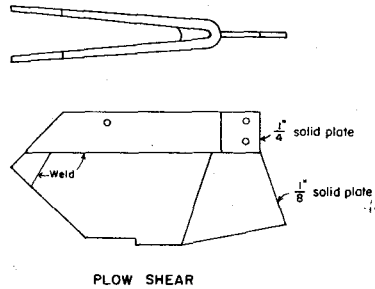
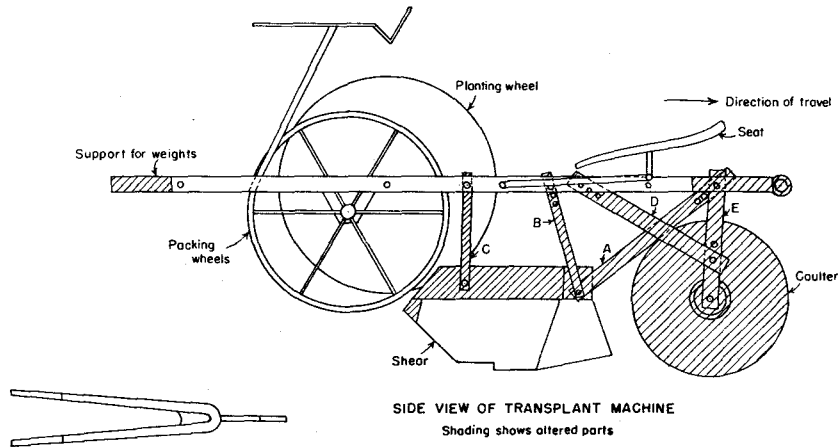
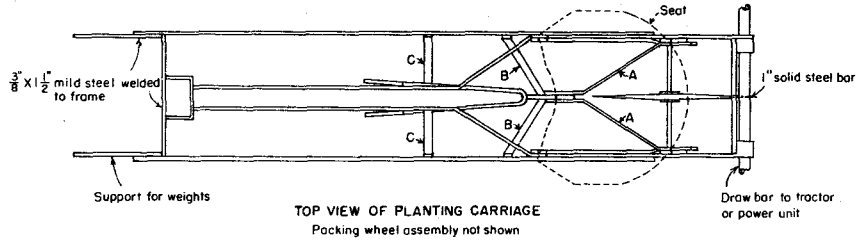

SQUARE POTS FOR TRANSPLANTS

Joe A. Downs

Nursery Manager, Albuquerque Nursery, S. C. S. Albuquerque, New
Mexico

Soon after the Albuquerque Soil Conservation Service -nursery was established in 1935, it became apparent that the usual method of handling evergreen stock for field use by farmers would not be successful. High quality open-rooted evergreen stock was being sent to the field and turned over to farmers for planting in windbreaks. The survival of this bare-rooted stock was exceedingly low. About five percent of the farmers obtained good survival, but the remainder had either a poor survival or a complete loss.

Most of the loss was due to improper handling at the time of planting, such as exposing roots to air for too long a period, planting in dry soil, or improper planting. Close supervision at the time of planting would have eliminated a small percentage of the failures, but the only way to get high survivals was to use potted stock.

To furnish potted evergreen stock to soil conservation districts at a reasonable cost, a potting bench was developed. This has proved to be successful in handling evergreen that are from 6 to 10 inches high at potting time. This bench was developed and constructed at the Albuquerque nursery by the author with the help of G. C. Niner, assistant nursery manager, and W. A. Horton, blacksmith. Details of the bench are shown in the accompanying drawing and photographs 1-4.

Fifteen-pound roofing felt is used as potting material. The 36-inch rolls are cut into 9-inch widths and then sliced with a paper cutter into rectangles 9 by 11 inches. The potting operations are ordinarily carried out under a large tent that affords protection to the seedlings from the sun and wind during the transplanting process.

Four men are required to handle one potting bench. Two actually pot the plants and two serve as swampers -- one to keep the operators supplied with soil, tarpaper sheets, and trees, and the other to carry away the trays of potted trees and place them in the establishment beds. Two potting benches require a crew of seven men -- four to pot the trees, two as swampers, and one as supervisor.

The potting bench consists of two potting units with the soil supply bin between the two operators. A 9 by 11-inch sheet of tarpaper is placed and formed in the potting box, a scoop of previously mixed soil is placed in the pot, partially forming it. The axis of the pot is horizontal. When the pot is about half full of soil, a seedling with roots spread naturally is laid in the pot with its root collar slightly below the top of the tarpaper. Filling is completed by putting another hand scoop of soil on the roots. The pot is completed by turning the handles to fold the edges of the tarpaper together and stapling them with a small hand stapler. The whole operation takes only a few seconds.

The potted plant is removed by pressing on a foot lever which pushes the false bottom of the box upward, enabling the pot to be easily grasped by one hand and placed in the carrying tray. The trays, which hold 12 2 1/2 x 2 1/2 x 9 -inch pots, are carried from the potting tent to the beds (photo 5). There the tray sides are lifted, leaving them on the tray bottom, which next is removed. The potted plants stand on the ground, 20 to the row. During the time required, the beds are held in place by 12-inch boards.

During the first few weeks of establishment, the beds are irrigated regularly by mist-type overhead sprinklers. Snow fencing is placed around the beds to reduce wind movement and lower transpiration. Stock is held in beds from potting time in late March and April until the shipping season in February and March of the next year.

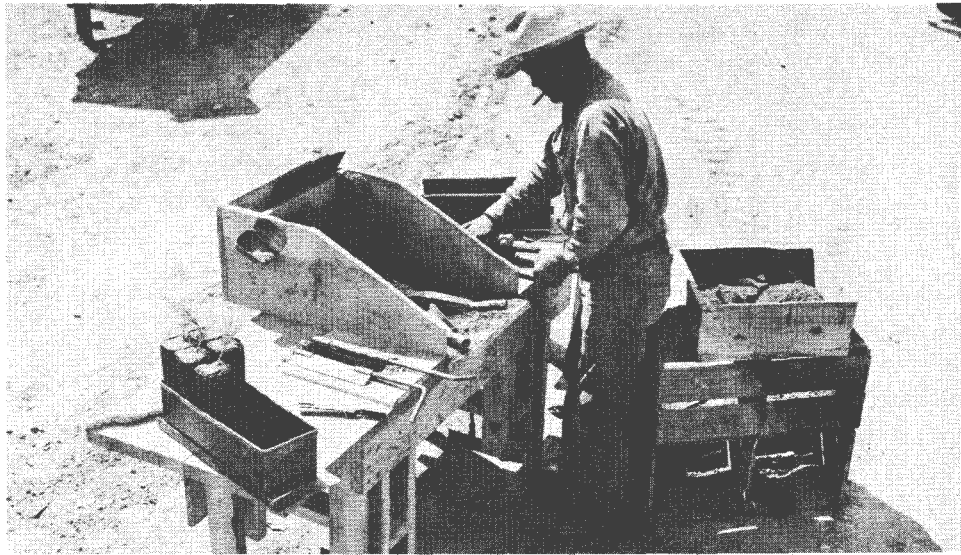

Potting bench constructed at the Albuquerque SCS nursery to facilitate placing conifer seedlings in tarpaper bands. One worker operates the device on the right side, another the device on the left. The soil supply bin is between them. The tree supply box would ordinarily be between the operators. Trays for carrying the potted trees to the growing beds are shown on either end of the bench.

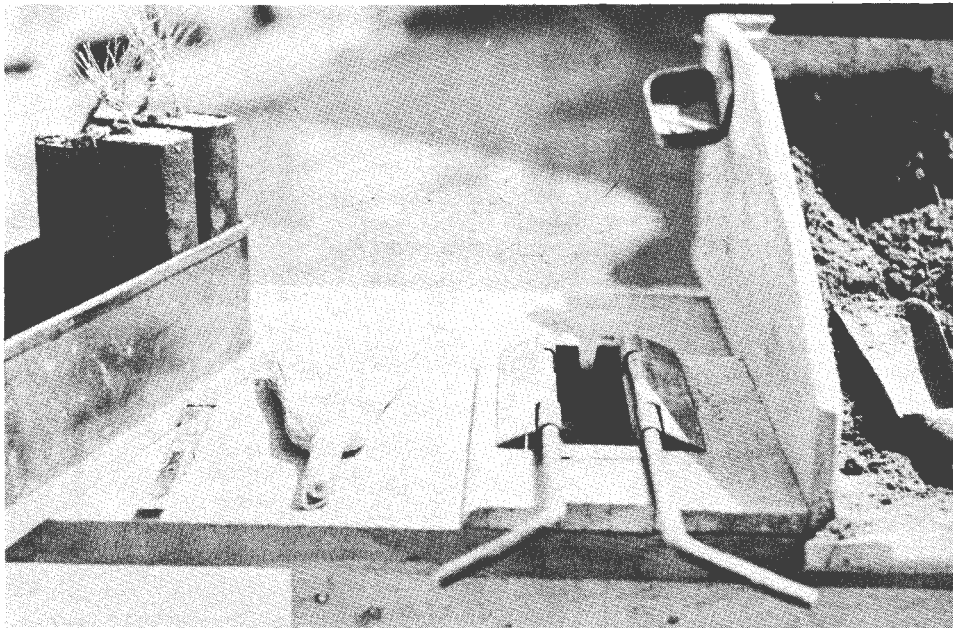

Close view from operators ' side of potting bench. The box for forming the pot is shown ready to receive the sheet of tarpaper in the first step of the operation. Soil supply is on the right and completed pots in carrying tray on the left.

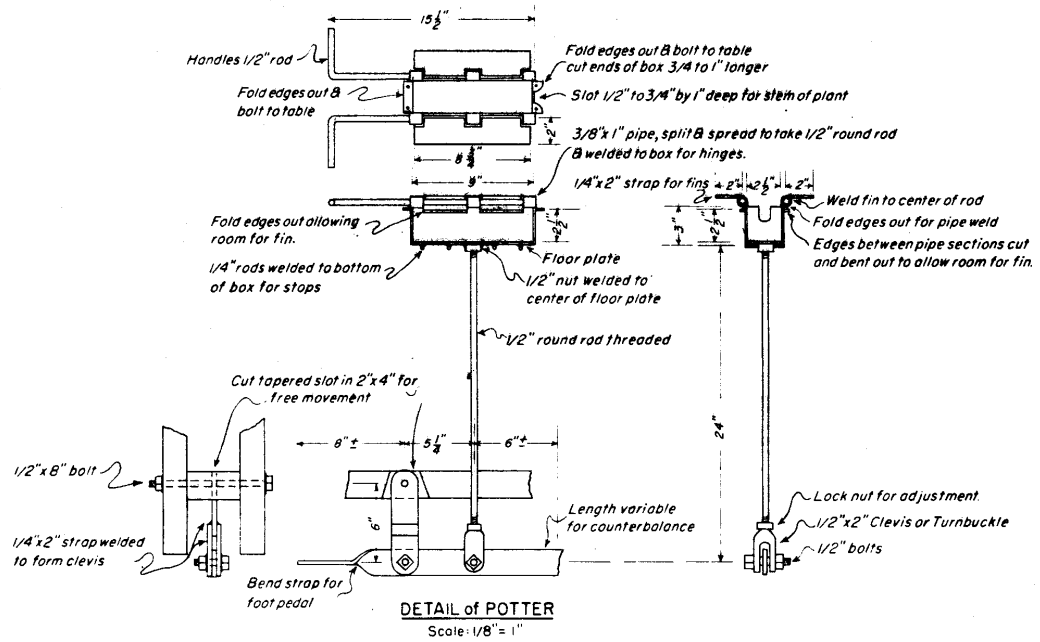
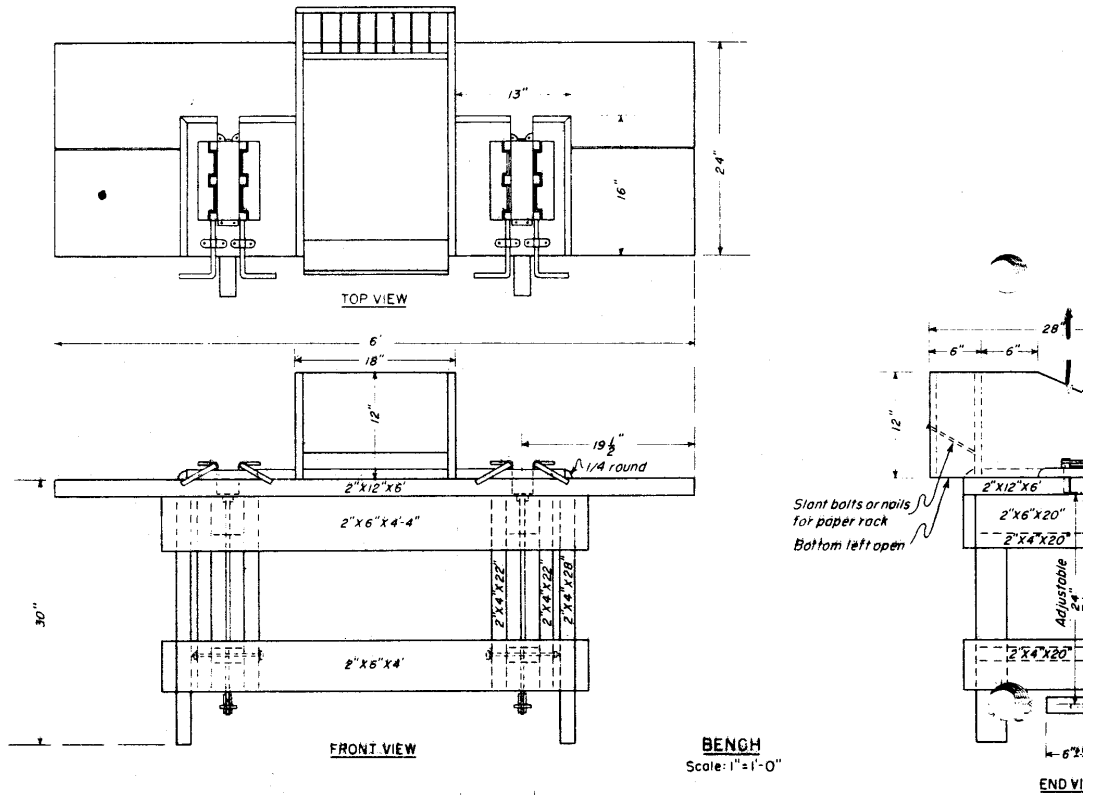

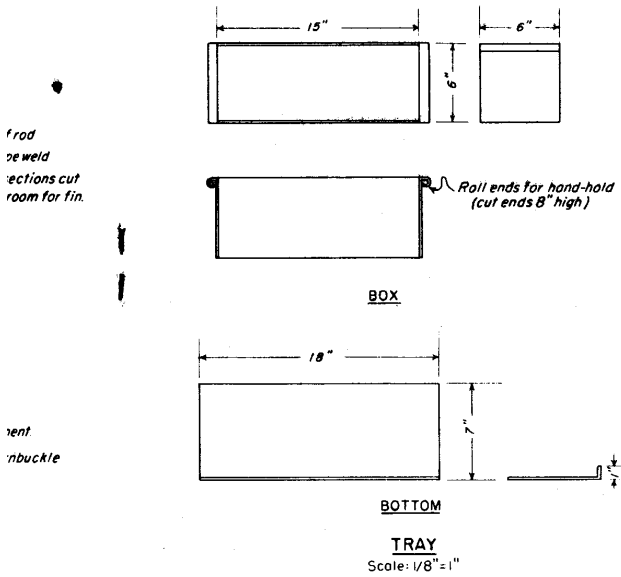
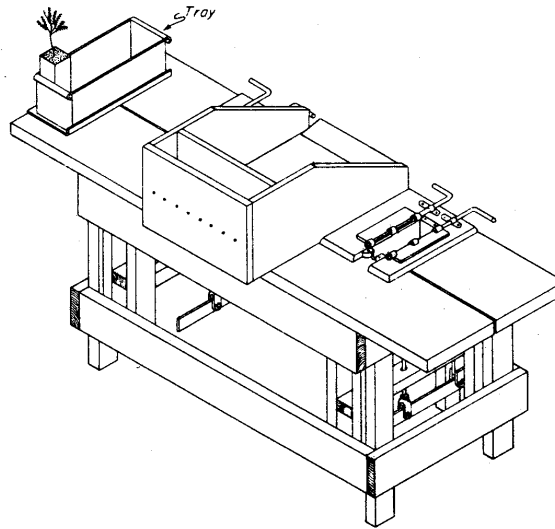
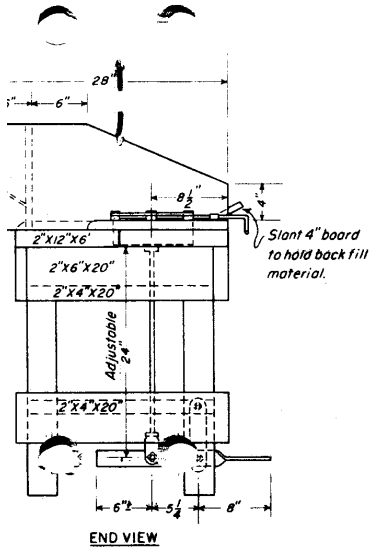

POTTING BENCH					
U.S. DEPARTMENT OF AGRICULTURE SOIL CONSERVATION SERVICE ROBERT M. SALTER, CHIEF					
SOUTHWEST REGION		CYRIL LUKER, DIRECTOR			
DESIGN	DETAIL H.D.G.	TRACE H.D.G.	CHECK	DATE	SCALE
	5-22-52	5-22-52			As Shown
APPROVED			FILE NUMBER		
			6-0-13608-2(2)		

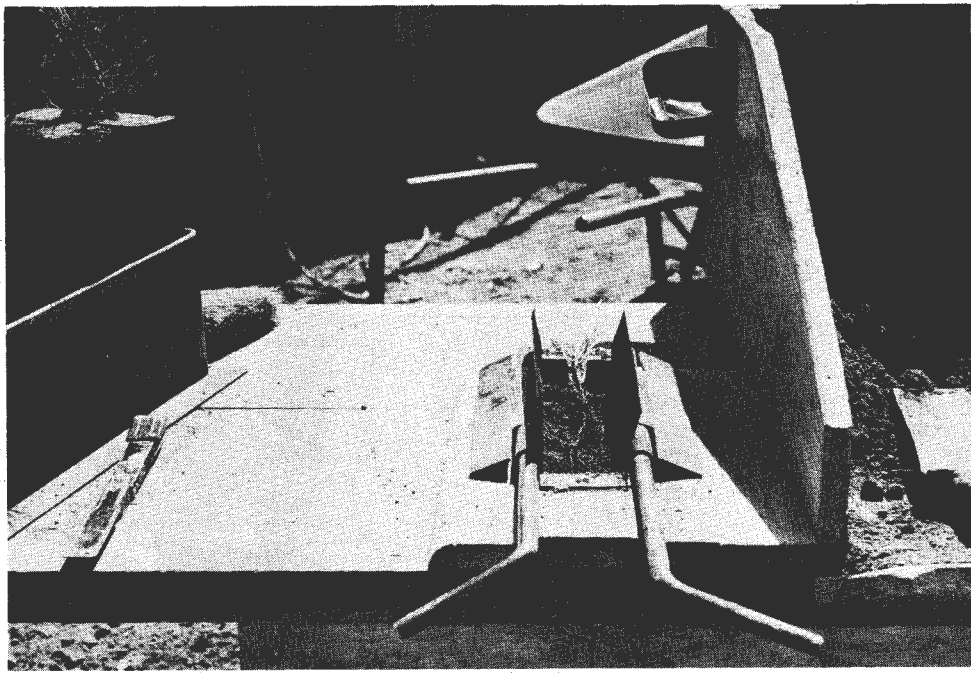

Close view of partially potted Ponderosa pine seedling in device.

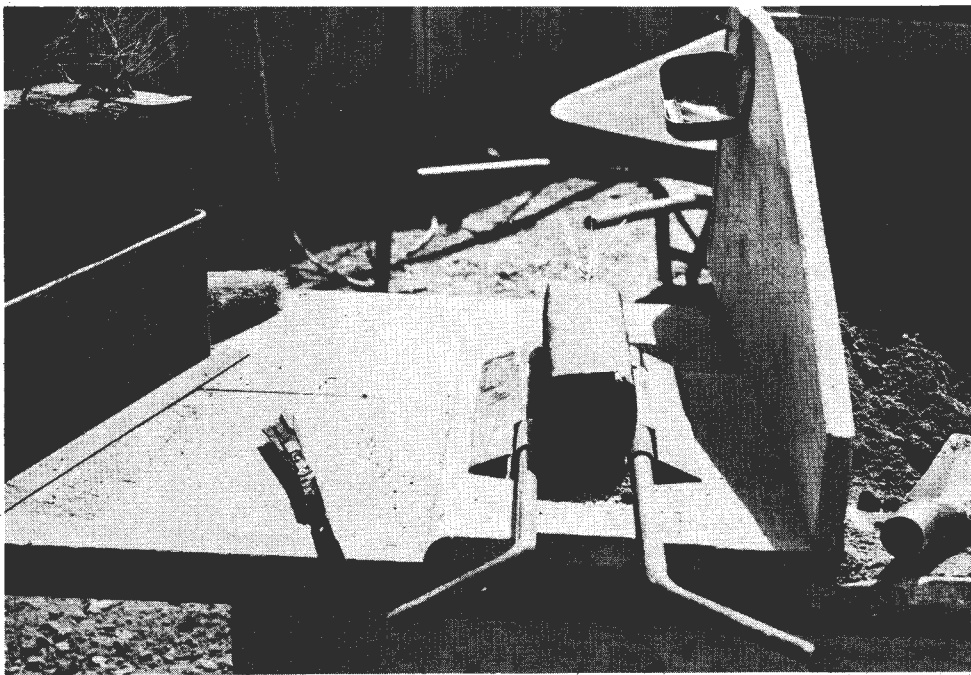

Potted Ponderosa pine seedling raised from box of potting unit and ready to be placed in carrying tray at left. The edge of the tarpaper is tacked down with small hand stapler shown. The completed pots are 2 1/2 x 2 1/2 x 9 inches.

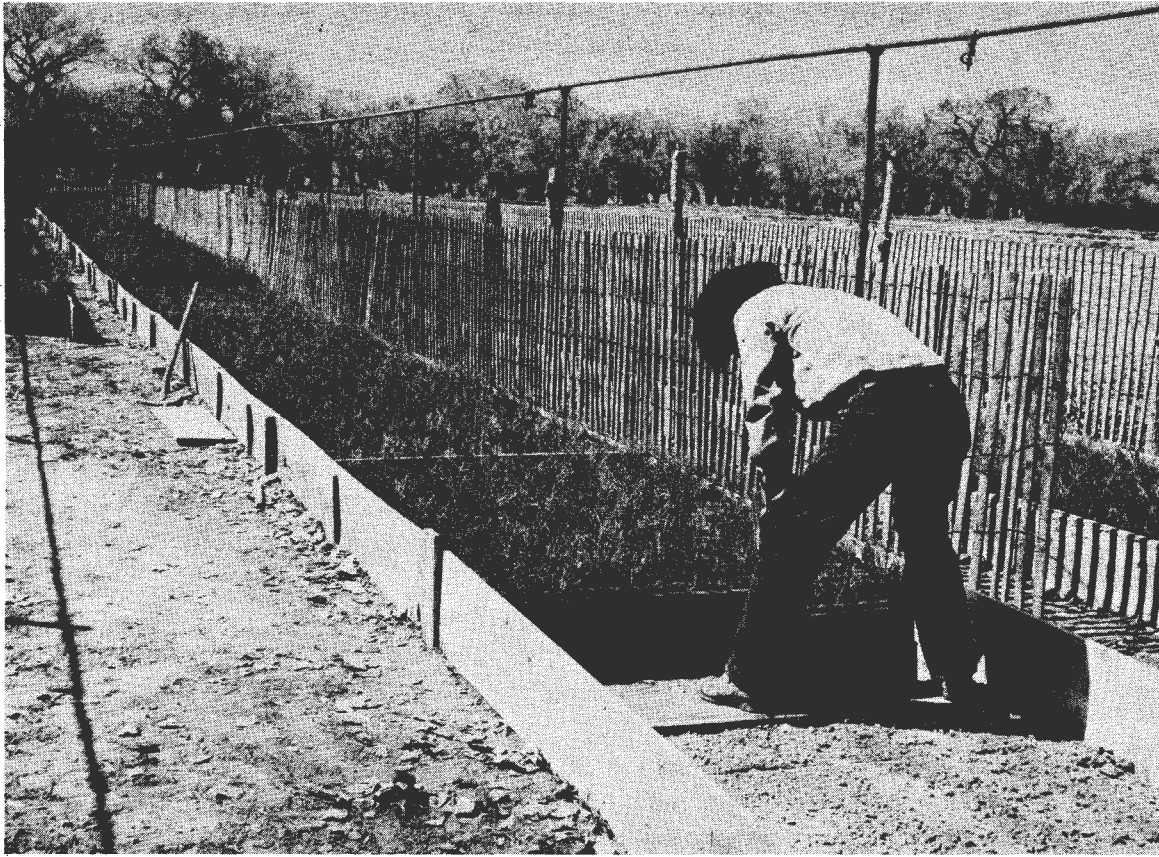

The beds where the potted conifers are placed for establishment. Stock is held in these beds from the time of potting in March and April to the following shipping season when they are removed from the beds, placed in boxes containing 30 pots each, and transported to the planting sites

The roofing felt costs \$5 per thousand pots and the labor for cutting it runs \$10 per thousand. Labor costs for potting the evergreens are approximately as follows: Four potters at \$6 a day, \$24; two swampers at \$6 a day, \$12; one foreman at \$11.50 a day, \$11.50.

A crew of this size will dig the seedlings, pot, and put into beds an average of 2,400 plants per day. The total cost of materials and labor will average about \$35 per thousand. This, of course, does not include the cost of the nursery stock used.

VALLONIA ROTARY TOOTH CULTIVATOR

Charles C. Mony
Nursery Superintendent, Vallonia Nursery, U. S. F. S.
Vallonia, Indiana

Cultivation of conifer seedbeds from the standpoint of weed control after seedlings emerge can be and is now largely eliminated by weed spray-- chiefly mineral spirits or solvent spray.

Post-emergence cultivation of hardwood seedbeds, however, is still necessary for weed control. This problem is solvable in part by mechanical, rotary-type cultivation. Our Vallonia Rotary Tooth Cultivator is used for this purpose.

In theory, the cultivator could be made with a line-shaft to cultivate a seedbed with any number of tree rows. Here at Vallonia we have a 4spool "battery" line-shaft for our 5-row beds and a 7-spool line-shaft for our 8-row beds.

Our machine has a tractor drawbar for use behind a light tractor as well as handles for the 2-man pulling method.

If it were not for chemical weed control we would have developed a self-propelled machine long ago. Since its use is now restricted to hardwoods (5 to 10% of our total production), our present machine has been adequate.

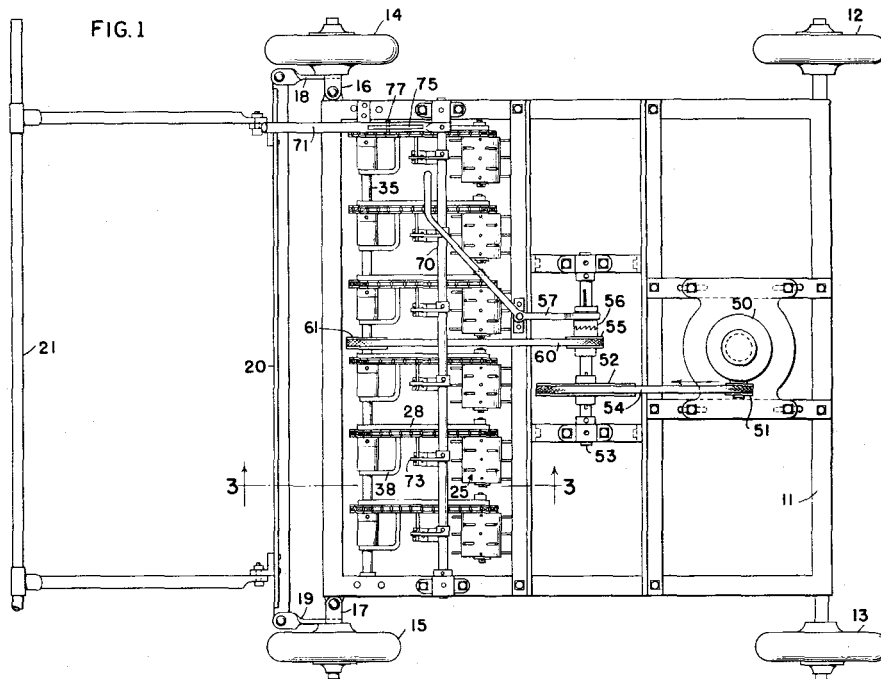

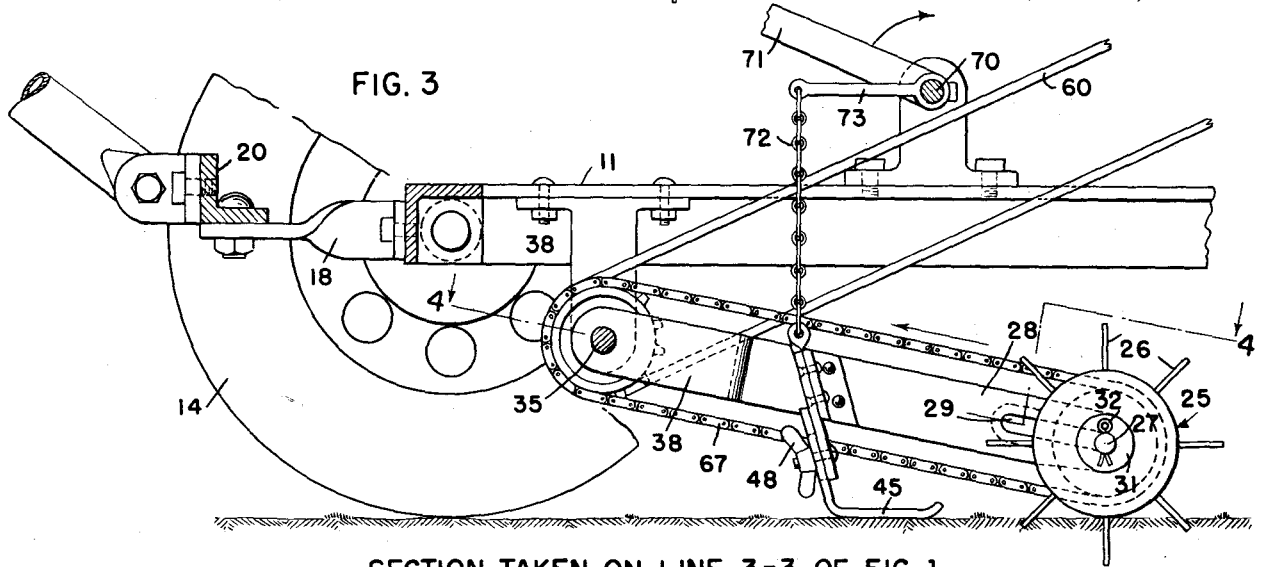
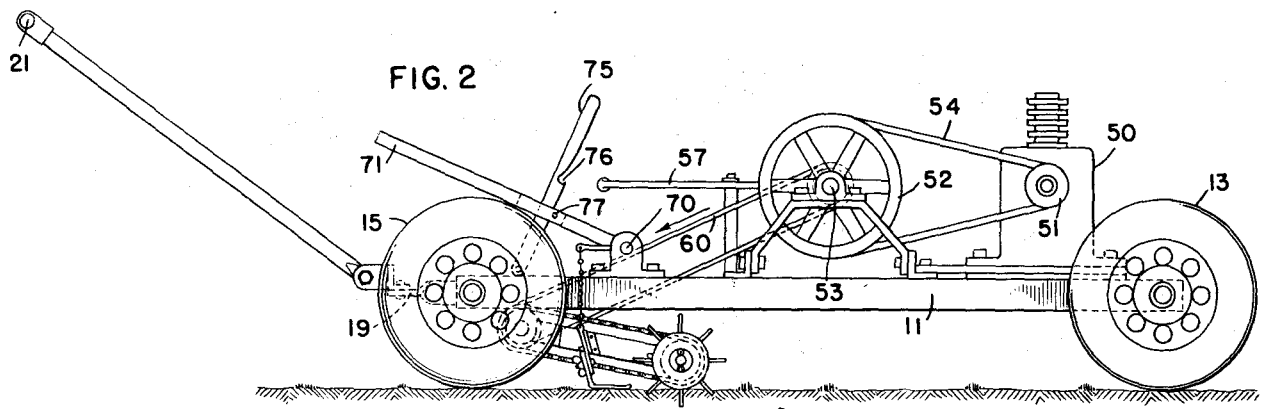

SECTION TAKEN ON LINE 3-3 OF FIG. 1

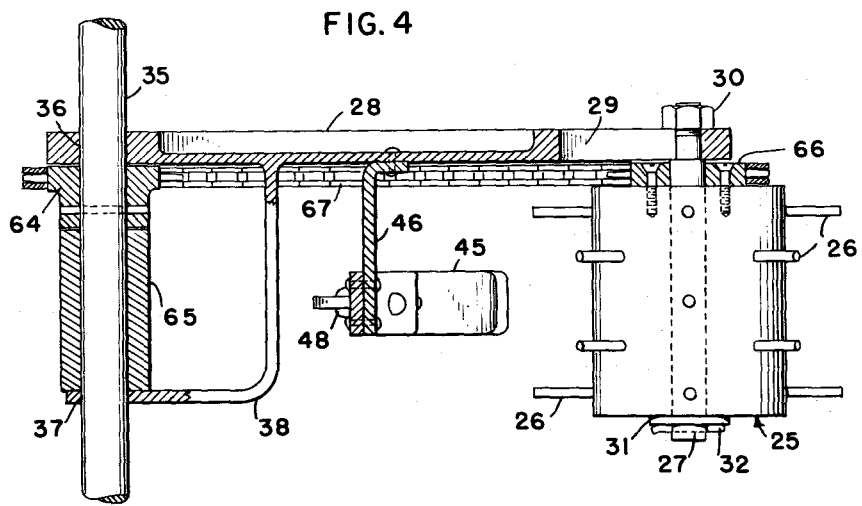

SECTION TAKEN ON LINE 4-4 OF FIG. 3

FIG. 5

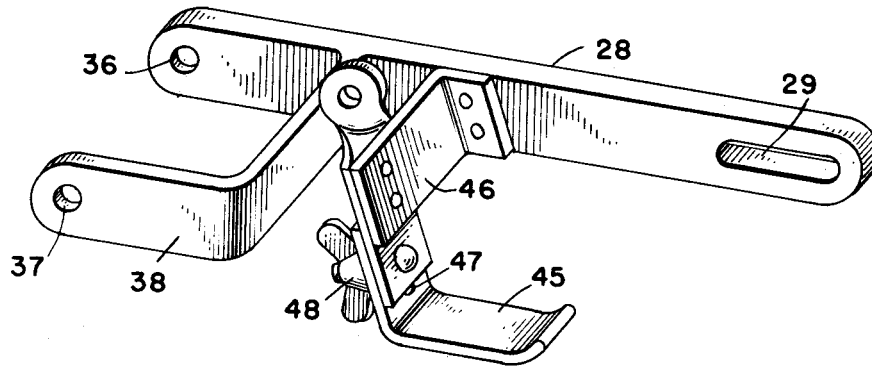

1. Rear Axle - 5/8" round shaft - 5'7" long.
8. Frame rail slot for belt #60, tension adjustment - 3/8" x 5".
9. Drawbar Handles - 3/4" pipe x 12".
10. Drawbar Tees - 3/4" pipe tees.
11. Frame members - 3/16" x 2" angle iron - #11 = 50"; #11A = 50".
- 12-15. Wheel barrow wheel and tire assembly (Standard item) (4.00 x 8).
16. Front wheel king pin assembly (R), 3/8" x 1 1/2" x 5".
17. " " " (L) "
18. King pin control rod (R) (Drag Links), 3/8" x 1 1/2" x 11".
19. " " (L) " "
20. Tie rod (connecting rod) 3/16" x 1 1/2" x 4'8" angle iron.
21. 2-man drawbar, pulling handle, 3/4" pipe x 48".
22. Pull shaft brackets - 3/8" x 2" x 2" angle iron.
23. Pull shaft swivel nuts - 3/8" x 1 1/2" SAE.
24. Pull shafts - 3/4" pipe x 33".
25. Cultivating spools - 3" x 3" lathe turned seasoned hardwoods, with 5/16" lathe cut holes.
26. Cultivating teeth, 1/2 nails set in drilled holes in #25. 25 teeth in 10 staggered rows of 2 and 3 teeth per row per spool.
27. Fixed spool shaft - 7/8" x 4 1/2", with 3/4" of thread (1/2") w/half nuts.
28. Cultivating assembly wishbones, 3/16" x 1 1/2" x 13".
29. Cultivating assembly wishbones, slotted ends, 1/2" x 4 1/2".
30. Lock nuts, of fixed spool shafts, 1/2" hex. half nuts.
31. Flat washers, spool retaining, outside, 7/8" hole.
32. Cotter pins, spool retaining 1 1/2".
33. Tooled thread of fixed spool shafts 1/2" - 3/4" of thread.
34. Flat spacing washer to be inserted on 27 between 66 and 29, 1/2" hole.
35. Line shaft, cultivation battery, 3/4" x 50".
36. Cultivating assembly wishbone, pulling side 3/4" hole.
37. Cultivating assembly wishbone guide side (hole) 3/4" hole.
38. " " 3/16" x 1 1/2" x 3"

39. Sprocket - spool screws 1 ½" F. H. wood screws.
40. Cultivating spool bearing (housing) 15/16" lathe cut hole in wood spool.
41. Sprocket setscrew, recessed for L-end wrench.
42. Sprocket collar (welded to sprocket) 3/4" hole in collar w/ #41.
43. Battery line shaft frame bearing hangers 1 1/2" x 1 ½" x 2" with 3/4" hole.
44. Chain lifting eye (and 44A).
45. Slotted depth adjustment feet, (shoes) 1/8" x 1 ½" x 5").
46. Depth adjustment brackets, 1/8" x 1" x 4".
47. Depth adjustment brackets, anchor nuts (optional size).
48. Depth adjustment wing nuts, 1/4" thread, w/1" bolt, w/slotted head.
49. Frame cross members, 3/16" x 2" x 50" angle iron.
50. Engine 1 H.P. , Continental "multitool", or Briggs & Stratton, etc.
51. Engine drive pulley, approx. 3", with 5/8" belt slot.
52. Reduction shaft master pulley w/setscrews, approx. 13", with 3/4" hole for 5/8" belt.
53. Reduction shaft - 3/4" x 16" (enough to allow room for clutch) NOTE: Continental "multitool" engine has a clutch built in.
54. V-belt, 5/8", engine to master reduction shaft pulley.
55. Reduction shaft drive pulley, 5/8" slot (oversize) x 3/4" hole x 3" diam.
56. Clutch - not necessary with "Multitool" engine - slip dog optional type.
57. Clutch handle or "rod" - any convenient arrangement.
58. Engine support and adjustment bolts - optional size.
59. Engine support frame rails w/sliding support bolt slots 3/16" x 2" x 20" angle iron.
60. V-belt 1/2", reduction shaft to cultivation battery drive pulley.
61. V-pulley, 1/2", battery drive pulley 6" diam. with 3/4" hole.
62. Reduction shaft frame, ¼" x 2" flat iron.
63. Reduction shaft pillow blocks (bearings) w/grease fittings 1 ½" x 1 ½" x 2" with ¾" hole.
64. Drive sprockets, cultivation battery, 10 tooth x 1" Pitch (Bicycle brake parts).
65. Hollow spacing cylinders, 3/4" pipe x approx. 2" length.
66. Cultivating sprockets 10 tooth (same as #64) drilled for #39.
67. Metal link roller chains, bicycle type, 1" pitch, w/master link.
68. Reduction shaft collars w/setscrews, with 3/4" hole.
69. Clutch rod fulcrum, any convenient arrangement.
70. Lifting assembly master shaft 3/4" pipe x 50" long.
71. Lifting assembly lever 3/4" pipe with 3/4" pipe tee.
72. Lifting assembly chains - 5" bronze window sash chain.
73. Lifting assembly "fingers" 3/8" rods, 5" long.
74. Lifting assembly master shaft bearings (to accommodate 3/4" pipe).

75. Lifting assembly stop rod 1/4" x 1" x 20".

76. Lifting assembly stop rod, notch (raised position).

77. Stop rod anchor stud w/pin (lifting assembly) on #71.

CONSTRUCTION COSTS FOR A GRADING TABLE

Lawrence C. Smack

Forester, Department of Conservation and Economic Development
Trenton, New Jersey

At one time or another we consider building something for the nursery, but there looms before us the specter of C O S T. Is it going to cost \$1, 000. 00 to save \$8. 95, or will the cost be reasonable and the saving in time and money worth while ? To help other nursery operators to estimate cost, we tabulated the materials and prices during the construction of a Forest Seedling Grading Table during the winter of 1950-51.

Briefly, the "table" is a continuous motor-driven belt with number and spaces for seedlings (see photograph). As the belt moves along the length of the table (17' 6"), "graders" on each side place two seedlings in the proper space indicated by numbers on the belt. Using ten graders, five on each side, and add each grader placing two trees per space, the output is 300 trees per minute, counted, graded, and ready for tying in bundles of 50.

The materials and 1951 prices for building the table are as follows:

2 pcs. 2" x 4" - 18' Douglas-fir -----	\$ 3.48
6 " 13 1/2" x 3/4" plywood circles---	4.90
2 " 1" x 8" - 12' #2 white pine-----)	10.34
4 " 1" x 8" - 14' #2 white pine -----)	
8 " 2" x 4" - 12' Douglas-fir-----	8.00
1 Steel shaft 1 1/4" x 52 1/2"-----)	5.37
1 Steel shaft 1 1/4" x 55" -----)	
4 1 1/4" solid journal bearings-----	9.60
4 1 1/4" steel collars-----	3.68
3 #BB468 platform aprons-----	48.00
1 66" V-belt 1/2"-----	2.30
1 1/8 H.P. electric motor with speed reducer-----	66.10
Assorted nuts, bolts, washers, etc.---	8.85
Switch, fustat, 25 ft. 14/2 flex. wire--	2.61
Labor, 80 hours-----	96.80
	<u>\$270.03</u>

**Materials on Hand
(Not included in cost)**

- 1 15" V-belt pulley (for 1 1/4" shaft)
- 1 2" V-belt pulley (for 5/8" shaft)
- 10 seedling boxes 24" x 18"
- 2 4" diam. 44" long wood rollers
- 90 lin. ft. 1" x 3" oak

Paint

The grading table is a complete unit with the power supply mounted underneath it. It can be plugged in and operated from any 110 V. outlet. -All bracing and construction is bolted so that it can easily be taken down for moving or storage. An electric switch was installed at the opposite end of the table from the motor and connected to the power supply by 14/2 flexible wire. This enables the men removing trees from the table to stop and start the belt at any time during its operation.

Using an A. C. 1/8 H. P. Janette Motor with gear speed reducer, the input is 1, 725 R. P. M. and the output 86 R. P. M. A 2" V-belt pulley on the motor shaft and a 15" V-belt pulley on the belt drum shaft gives a belt speed of one revolution in 59 seconds. This speed is satisfactory for 2 trees per number, 50 trees per bundle. Speed of the belt should be reduced if more than 2 trees are placed on each number.

In addition to identifying each "grader" by number, we gave each number on the belt a different color and painted the corresponding color on the table in front of each grader. Most graders find it easier to identify their individual seedling space on the belt by color rather than number.

To obtain the maximum efficiency from the grading table, we recommend the use of a tying machine. A foot operated tying machine can be purchased for \$90.00.

In the first year of using the grading table and tying machine, a reduction of 20% in total hours for grading, counting, and tying was found possible in comparison with previous labor methods. This reduction in hours was achieved despite an 8% increase over the previous year in production.

