

L. M. Futrell, Stuart Nursery, U.S.F.S.
Pollock, La.

The present method of raking seedbeds by hand preparatory to sowing takes considerable time and labor when both of these commodities are at a premium. Use of a bed smoother eliminates hand labor and saves time with no additional tractor power needed. The estimated saving is \$ 15 per acre, or \$ 750 to \$ 800 during each spring sowing season at the Stuart Nursery.

The seedbed smoother is a sledlike apparatus, which is dragged over the seedbed behind the tractor shaping the bed. It was constructed from scrap materials in the dimensions shown (fig. 1). The sled section is made of 1 -inch pipe welded at all joints. The frame of the floating section is of the same material and is suspended at four points to the sled section by chain. The rear cross member of the floating section is made of 20-pound railroad steel to provide necessary weight to hold the cross chains to the bed. The chains were salvaged from truck tire chains, but twist link chain or well chain will be satisfactory. The cross chains slope to the rear from the ridge chain and are fastened to the sides of the floating section at an angle of 45 degrees by wire through holes in the pipe. The smoother is pulled by 5/16-inch welded chain fastened to a hole in the tractor drawbar with a clevis. The tractor drawbar rides about 16 inches above the seedbed.

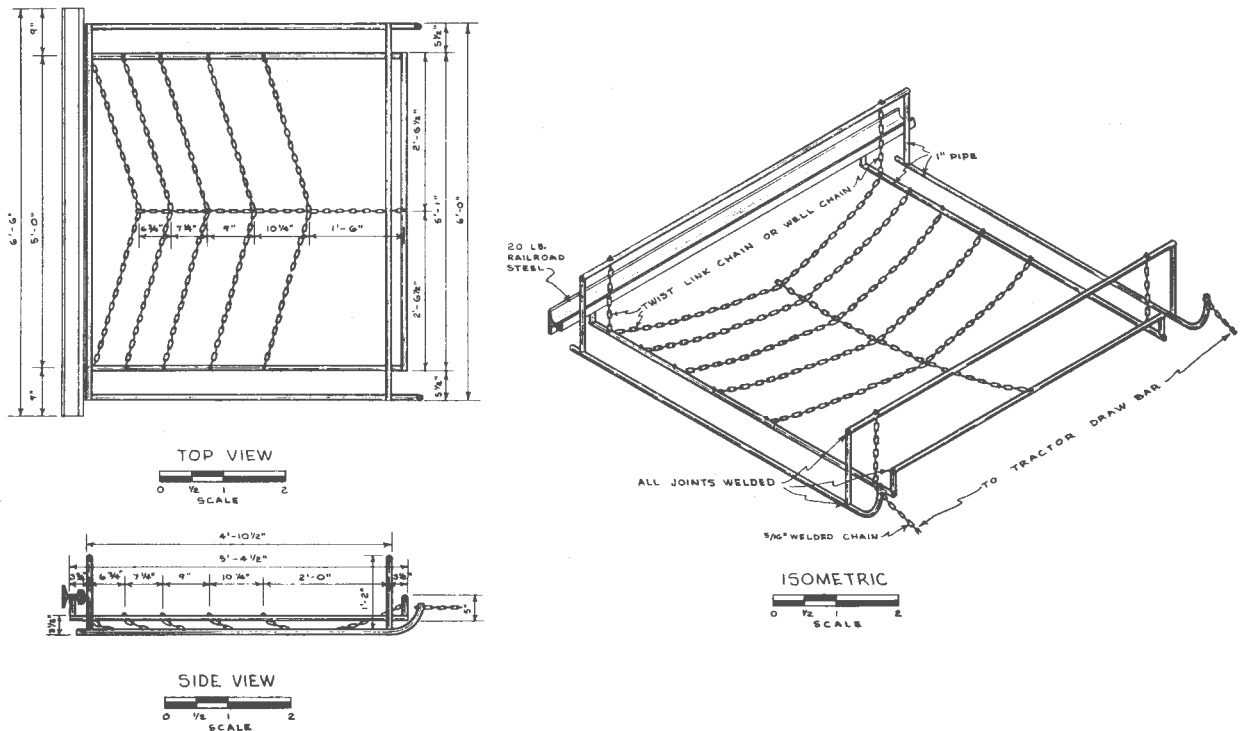

Figure 1.--Seedbed smoother.

PACKING TABLE FOR BUNDLING SEEDLINGS

G. W. King, Nursery Superintendent
Department of Conservation and Development
Providence Forge, Va.

A packing table for bundling seedlings has been developed in our nursery and improved over a 10-year period (figs. 1 -2). We now have eight tables in operation, a number adequate for packing 1 million seedlings in 8 hours.

Some of the advantages of this table are as follows:

1. Table is designed to be compact and to take a minimum of floor space.
2. Each table is a compact unit. Even the steel tape reel is built in.
3. All material for packing is within easy reach of the operator.
4. By using the interchangeable and adjustable front board, all sizes of packages can be handled on the same table.
5. A handy tool shelf is directly before the operator.
6. The aluminum channel tape guide is most helpful and makes it possible to use either front feed or back feed tape tightening machines.

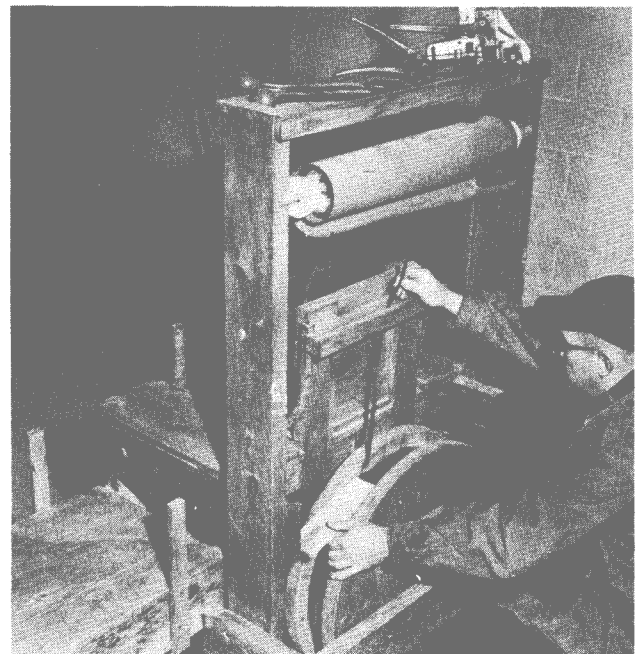

Figure 1--Packing table: Left, Steel tape being fed into aluminum channel guide; right, steel tape being brought from tape reel into position for bundling.

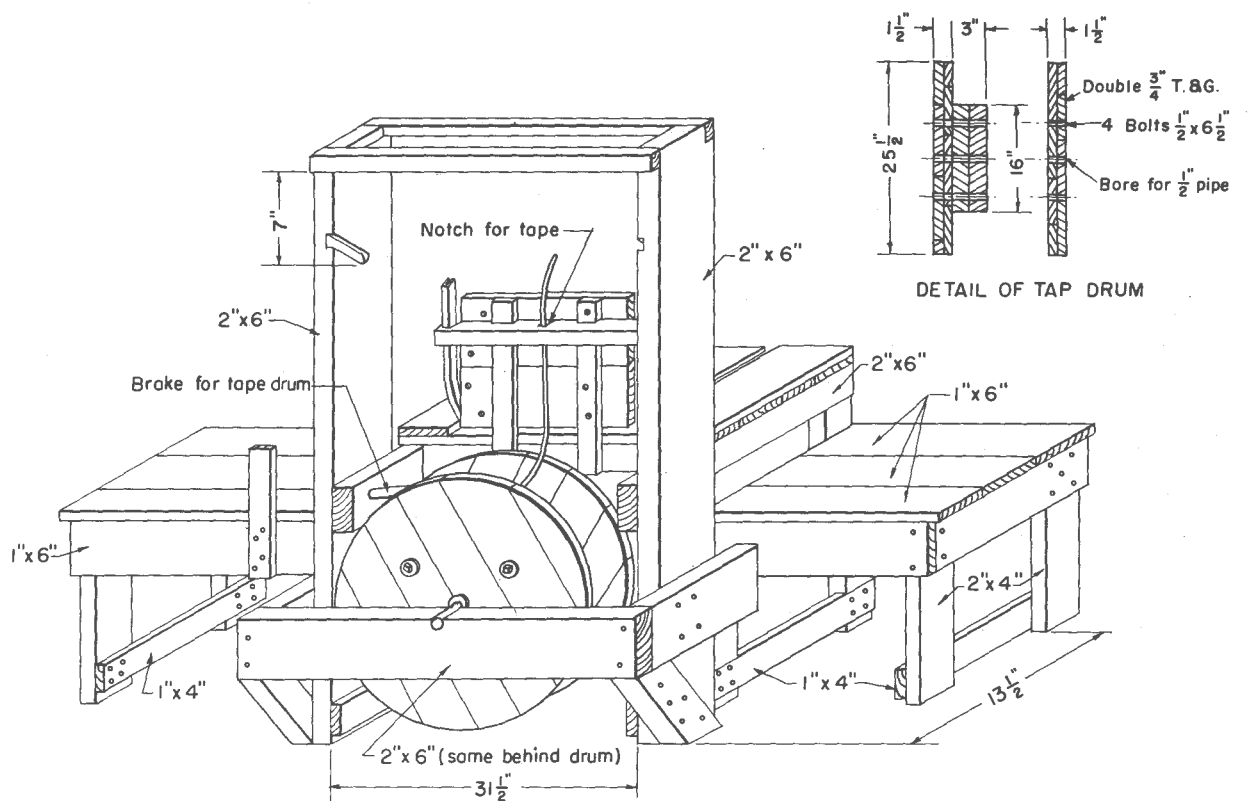
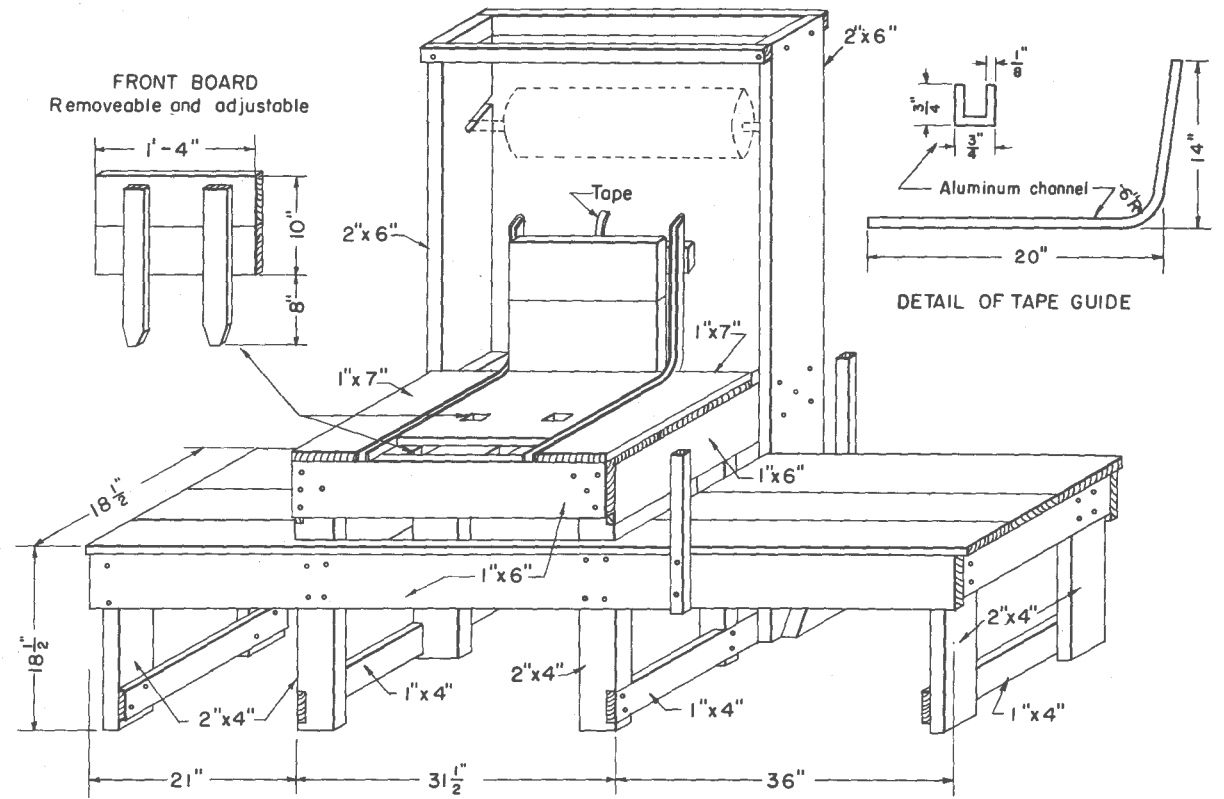

Figure 2.--Front and back of packing table.

STEEL STRAPPING TREE BALER

H. G. Hertel, Nurseryman
 Iowa State Conservation Commission Nursery, Ames, Iowa

A baling machine was constructed at the State Forest Nursery from a blueprint sent by the Southern Region, U.S. Forest Service, and from photographs of balers used in Georgia. The baler has been most satisfactory (fig. 1). We use a heavy Kraft paper with reinforcing cord and asphalt as a center ply and steel strapping for tying the bale. Since the roll of paper is mounted above the baling surface, it is not necessary to cut the paper until the trees are in place in the bale. This eliminates waste since the operator knows exactly how much paper he will use.

Signode seal feed strapping machines were the ones chosen, and they have proved to be excellent. This machine tightens the strapping, fastens the seal, and cuts the strap—all accomplished with the one tool. Again there is no waste since the excess strap gained in tightening the bundle is fed back to the strapping supply reel.

The steps in baling are as follows:

1. The strap is led across the bottom of the baler in the position where it will hold the bale (fig. 2).

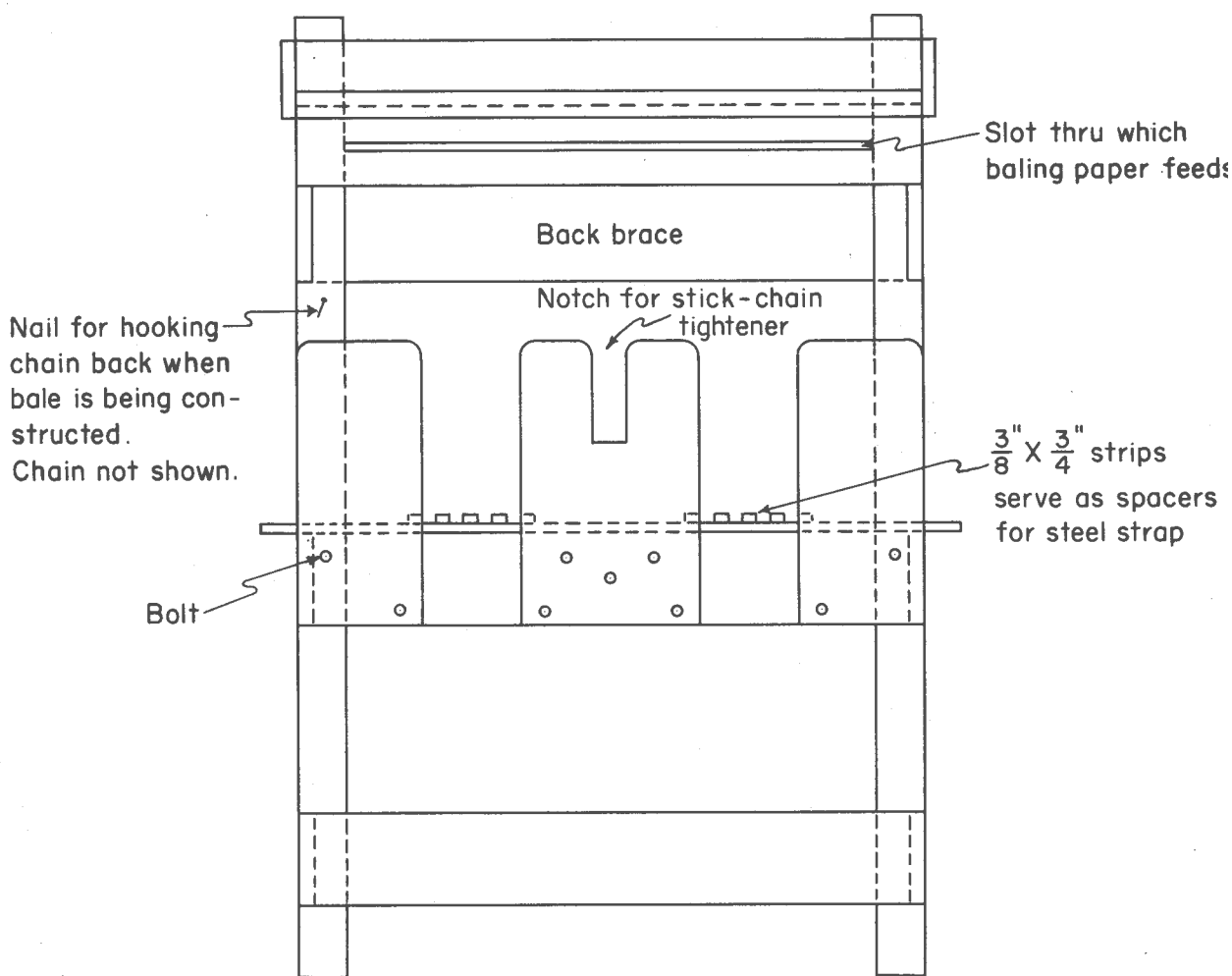

Figure 1.--Steel strapping tree baler, front view.

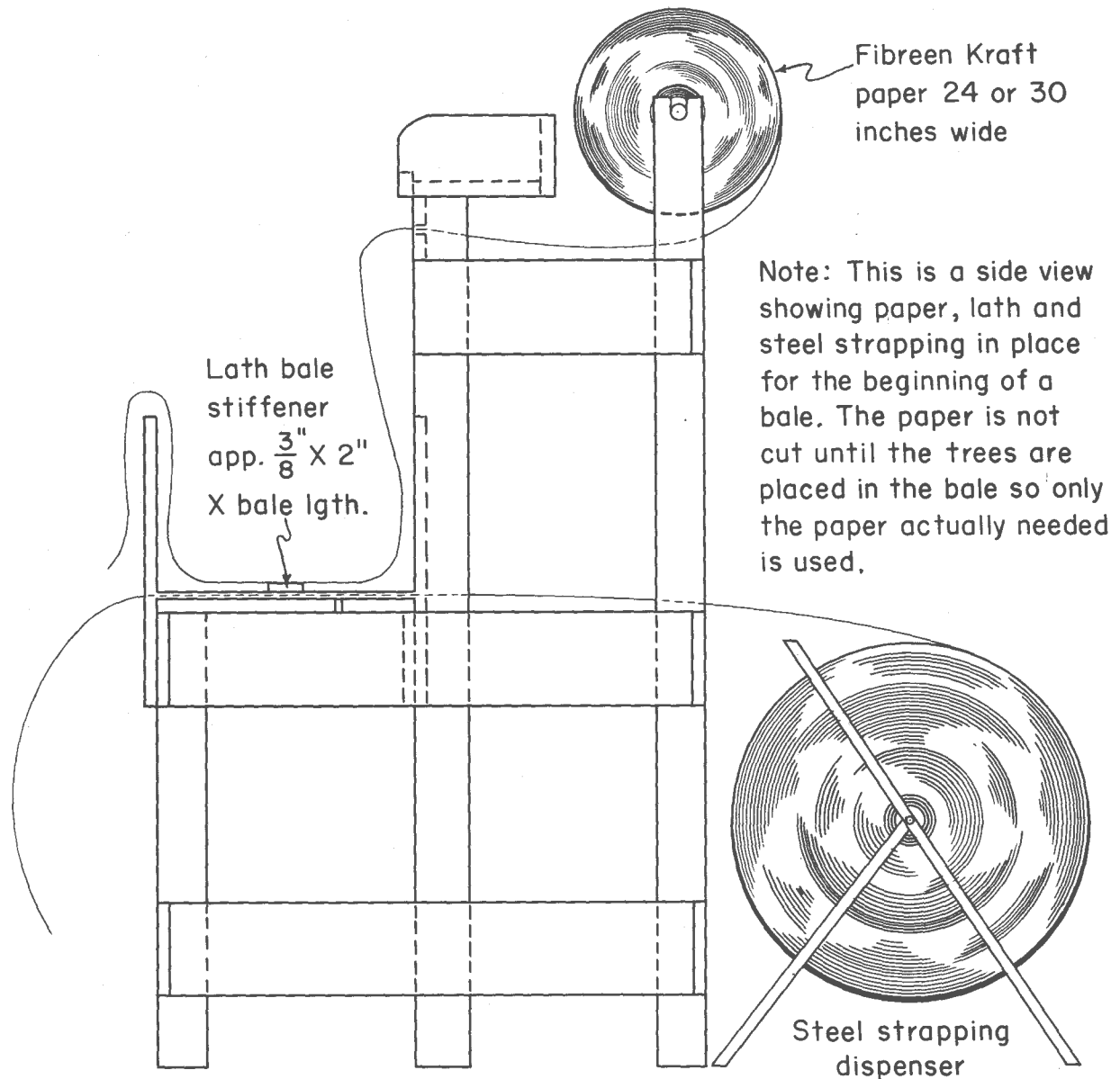

Figure 2.--Steel strapping tree baler, side view.

2. A stiffening lath is placed over the strap and will eventually prevent bending of the completed bale.
3. The paper (24 or 30 inches, in our operation) is placed in the baler so that the trough is covered, and an end about 12 inches long hangs over the front.
4. Alternate layers of moist sphagnum moss and trees are placed in the paper "trough."
5. The paper is cut at the required point and the two ends rolled by hand around a lath.
6. The chain and stick clamping arrangement prevents loosening of the bale while the strapping machines are put in place (fig. 3).
7. The clamping stick is removed and the bale is complete.

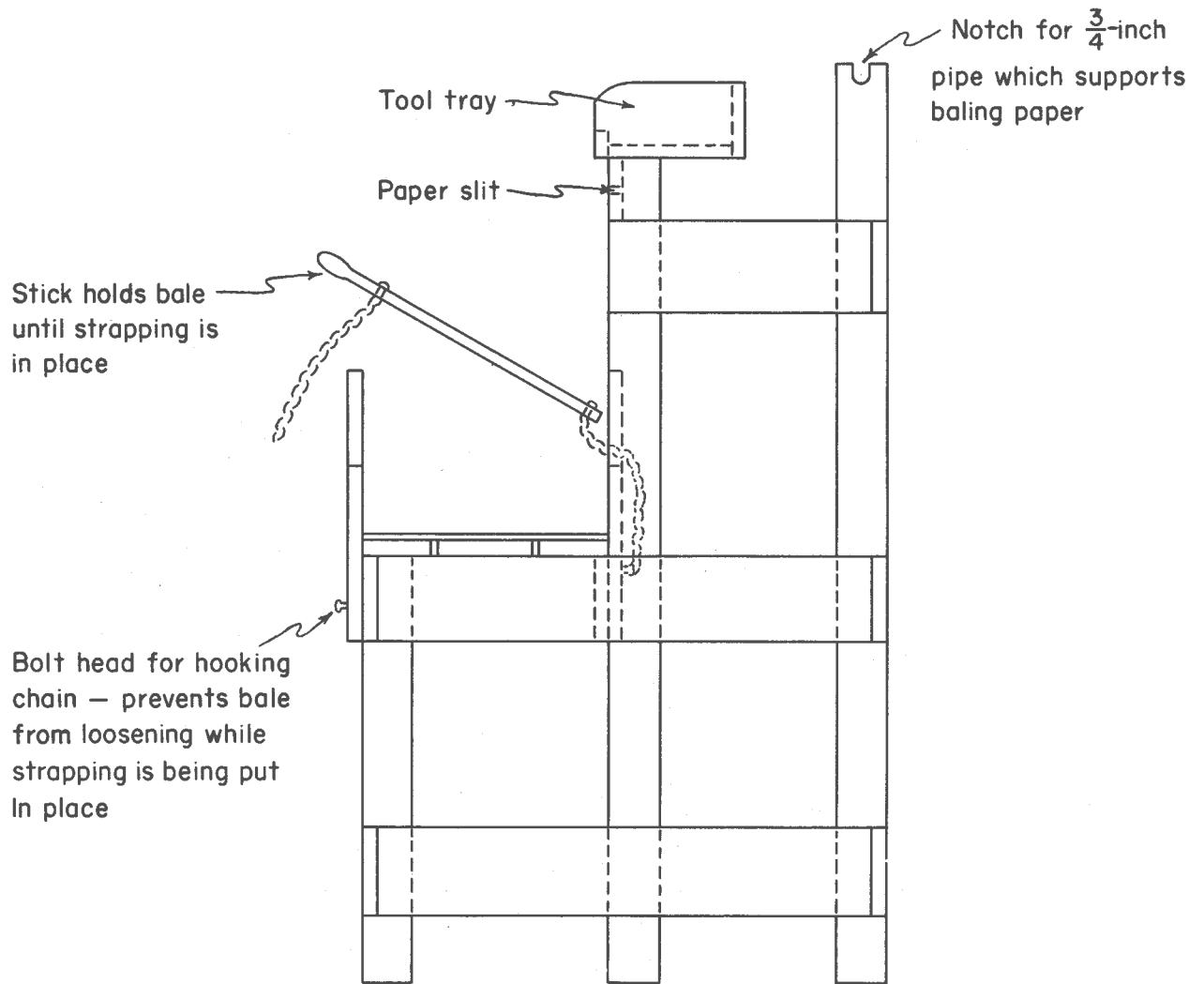

Figure 3.--Steel strapping tree baler, side view.

This method has proved to be simple, conservative of materials, and versatile. Hardwoods and conifers in varying sizes of package may be handled with the same baler. Much of our stock is shipped by railway express, and these bales, which defy rough handling, give no breakage problems.

SIMPLIFIED TREE INVENTORY COUNTING FRAME

E. J. Eliason, Superintendent of Nurseries,
New York State Conservation Department, Albany, N. Y.

An open-end counting frame has been devised at the Saratoga State Tree Nursery. Heretofore, a similar frame has been used to define the sample area for taking the tree inventory in the nursery seedbeds. The older frame was completely enclosed, which meant that it had to be pushed down into the trees from the top to reach the ground. This was often difficult and consumed time to properly separate the tree stems that should go either in or out of the frame. The frames are made so that the inside length is the linear distance wanted; therefore, tree stems should fall in or out in relation to this inner edge. The new frame with an open end permits it to be applied from the side by sliding it through the seedlings at ground level (fig. 1). This works faster, and the sharper points differentiate the in and out tree stems automatically.

To support the open end and to serve as a handle, one wicketlike arch is attached about two-thirds of the distance from the closed end. This arch should be high enough to clear the normal heights of nursery trees.

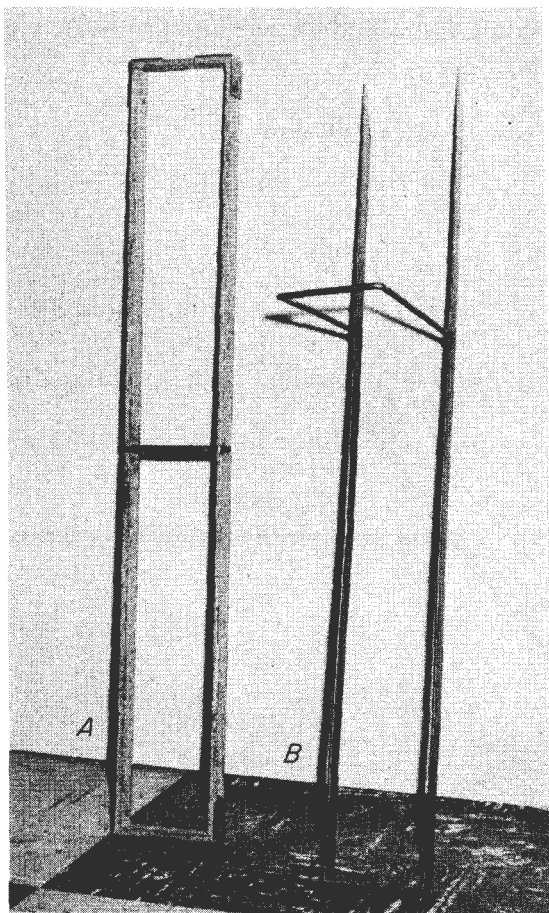

Figure 1.--Inventory counting frame: A, Old style, closed ends, made of wood reinforced with metal at corners; B, new style, open-end, made of aluminum bar, 6 inches wide, inside measurement, and 48 inches long.

Material for the frame should be light in weight and rigid. Wood can be used but should be reinforced with metal at the corners. The frame constructed of bar aluminum seems satisfactory. The aluminum material is one-quarter of an inch thick and one and one-quarter inches wide. The frame must hold firmly to the wanted inside distance, since any material deviation will affect the tree count. In using this frame, or one similar, this measurement should be checked frequently for possible adjustment.

This improvement, like many others, is the work of several people. The need for a better frame seems evident after years of experience with the older one. Those contributing were Elmer Terrell, forester, and Richard E. Wilson and Gerald Hughes, nurserymen, Saratoga Nursery. Messrs. Wilson and Hughes received \$100 from the Merit Award Board of the State Department of Civil Service for this suggestion. This amount was based on the fact that the frame will save State nurseries about \$1,000 a year.

This frame may have other applications where a quadrat or other sampling is taken, such as on a range survey, or on tree reproduction or other ground cover studies.

THE HOLLAND TRANSPLANTER, FURTHER MODIFICATIONS
OF THE -SHOE TO IMPROVE ROOT POSITION

Karl B. Lanquist
Nurseryman, Mt. Shasta Nursery, U.S.F.S.
McCloud, Calif.

The March 1954 issue of Tree Planters' Notes carried an article on modifications developed at that time on the Holland transplant machine. However, further improvements are now necessary because: (1) The shoe did not complete the trench in time for the tree to be released and secured by the packing wheel, and (2) soil shifted in between the upper half of the shoe and the packing wheel. To correct these defects we found it necessary to add (fig. 1):

- A. To the depth of the shoe.
- B. About 3 inches to the length of the shoe.
- C. A strip close to the packing wheel.

As a result of these changes, planting will be well done if the roots are all pruned to about the same length, and if the trees are placed in the same and correct position in the rubber clips. The problem of bent roots should not occur.

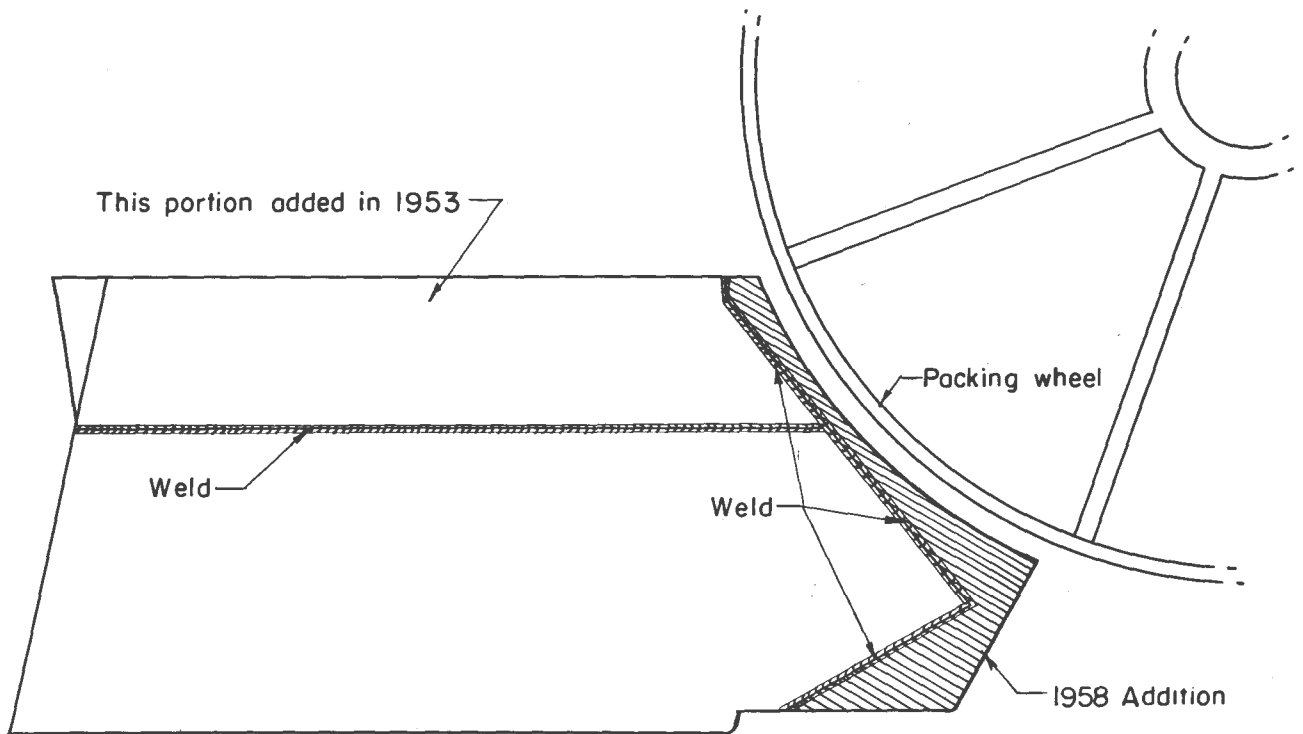

Figure 1.--Shoe modification for Holland transplanter.

NOTES ON NURSERY PRACTICE IN SCOTLAND

Henry I. Baldwin
New Hampshire Forestry and Recreation Commission, Concord, N. H.

The influence of a damp, cool climate is very apparent in most nurseries in western Scotland. Artificial watering is rarely essential, and a cover over seedbeds may be needed for a short time only. Weed growth is less rank and rapid than in warmer climates. All these facts contribute to easing the lot of the nurseryman, but on the other hand there is greater need for good drainage and maintenance of fertility.

Many private estates maintain their own small nurseries, and here one finds some excellent stock being grown in an intensive way with no labor-saving devices, to be sure, but by gardeners who have inherited a "green thumb" from their fathers and grandfathers. An example of the Dünneman seedbed may be seen at Murthly Castle in Perthshire (fig. 1).

The method used on this estate was developed by a forester in the Harz Mountains of Germany and will delight the organic gardener for it is merely growing trees in their own humus. The bed is prepared by turning over the soil, then building a frame 12 to 18 inches high of boards which is filled to the top with duff from the forest (i.e., Norway spruce), mixed with some mineral soil. Seeds are sown on the top and covered with grit. Obviously, such a bed is well drained and in a less damp climate would need shading and constant watering. The advantages claimed are a longer growing season (warmer soil), less weeding, and a saving of 1 year in producing stock. One-year seedlings are sometimes transplanted to ordinary soil so that they will not become too spindly. Because of rapid shoot and root growth in the box plant, density must be kept low.

At the other extreme the large nurseries operated by the Forestry Commission for supplying stock to government reforestation projects are highly mechanized. Ledyard Nursery is a good example with 56 acres in seed and transplant beds. Seeding is done in drills with a special tractor-drawn machine, which prepares the furrows, rolls them, deposits the seeds, and covers them with grit (ground stone) (figs. 2 and 3). Rows are 300-500 feet long. These seeded rows are undercut to prune the roots instead of transplanting.



Figure 1.--Dünneman seedbeds, Murthly Castle, Perthshire, Scotland.

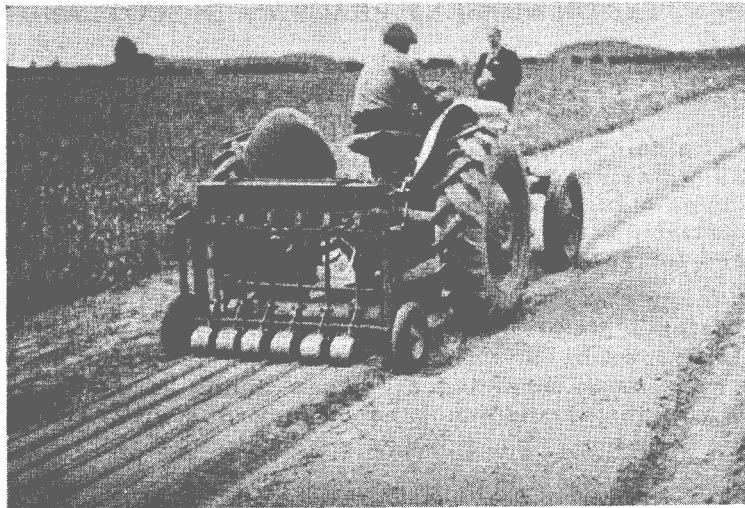

Figure 2.--Woodburn's seeder that prepares and rolls furrows; drills seed and covers them with grit.

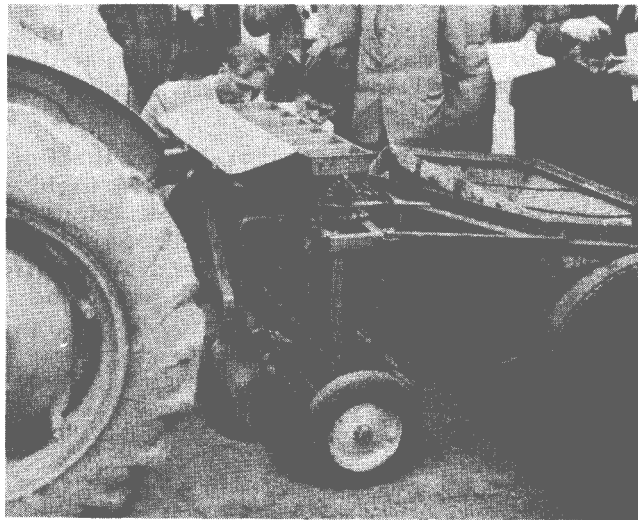

Figure 3.--Woodburn's seeder with covering machine, Ledmore Nursery, Perthshire, Scotland.

But some transplanting is still done using a locally designed machine called a lining-out plough. This lining-out plough pushes the soil against a line of 10-foot transplant boards in place and at the same time opens another furrow for the next row, spreading a stream of fertilizer in the bottom of the furrow as it goes (fig. 4). Two of these ploughs permit 250,000 seedlings to be transplanted per day at an average cost of 4 shillings per thousand.

The nursery now produces 6 to 7 million trees per year (fig. 5), but will have three times that output when all the ground is in production. About 30 workers, mostly women and boys, are employed at peak seasons; 20 at other times. At the present time Sitka spruce, Douglas-fir, and Japanese larch are the chief species produced; lesser quantities of Norway spruce, Scotch pine, and European larch are also produced. Fertility is maintained largely by crop rotation and cover crops plus manure.



Figure 4: -Woodburn's transplanter opening furrow and spreading fertilizer; transplant boards in place.



Figure 5.--Douglas-fir transplants set with Woodburn's transplanting machine, Ledmore Nursery.

Some of the machines used at this nursery are the lining-out plough, the drill sowing machine, the twin-bladed undercutter for root pruning, the "Gunn" plant lifter, and the Steerage weeding hoe. The plant lifter has semicircular tines that travel between the rows to reduce root damage; and the weeding hoe cultivates between the rows (fig. 6).

The person who developed the various machines is T. A. Woodburn, District Forest Officer of the East Scotland Conservancy in which the nursery lies. His imagination and inventive ingenuity are so great that sometimes models of his machines become obsolete before being fully perfected.

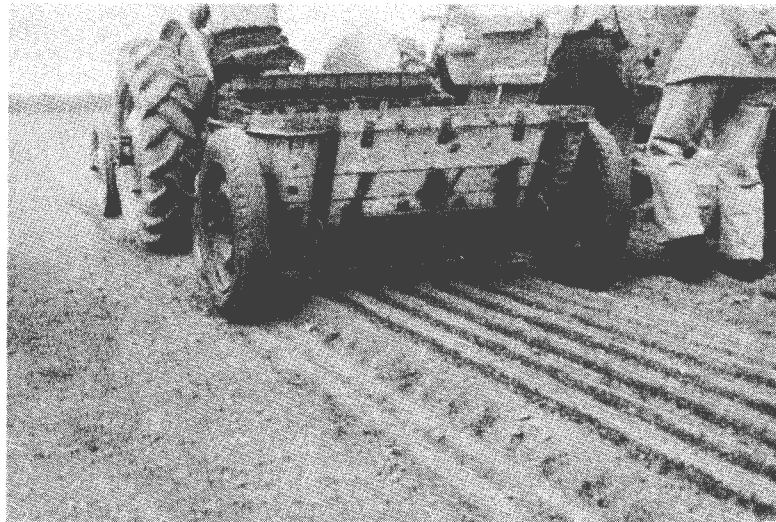

Figure 6.--Woodburn's row cultivator, drill marker, and fertilizer.

SIMPLIFIED HAND WEEDING TOOL

Homer Ward, Nurseryman
"Mike Webster" State Nursery, Turnwater, Wash.

The Ward weeder is a weeding tool that has proved most effective. It is made in the nursery shop from a 6-inch length of 1/2-inch thin-walled conduit. A section 2-1/2 inches long is cut away with a hacksaw and shaped on an emery wheel (fig. 1).

The forerunner of this tool was the common vegetable peeler, effective but short lived for this work. A homemade weeder lasts indefinitely. This cost is nominal, material 5 cents, labor 15 cents.

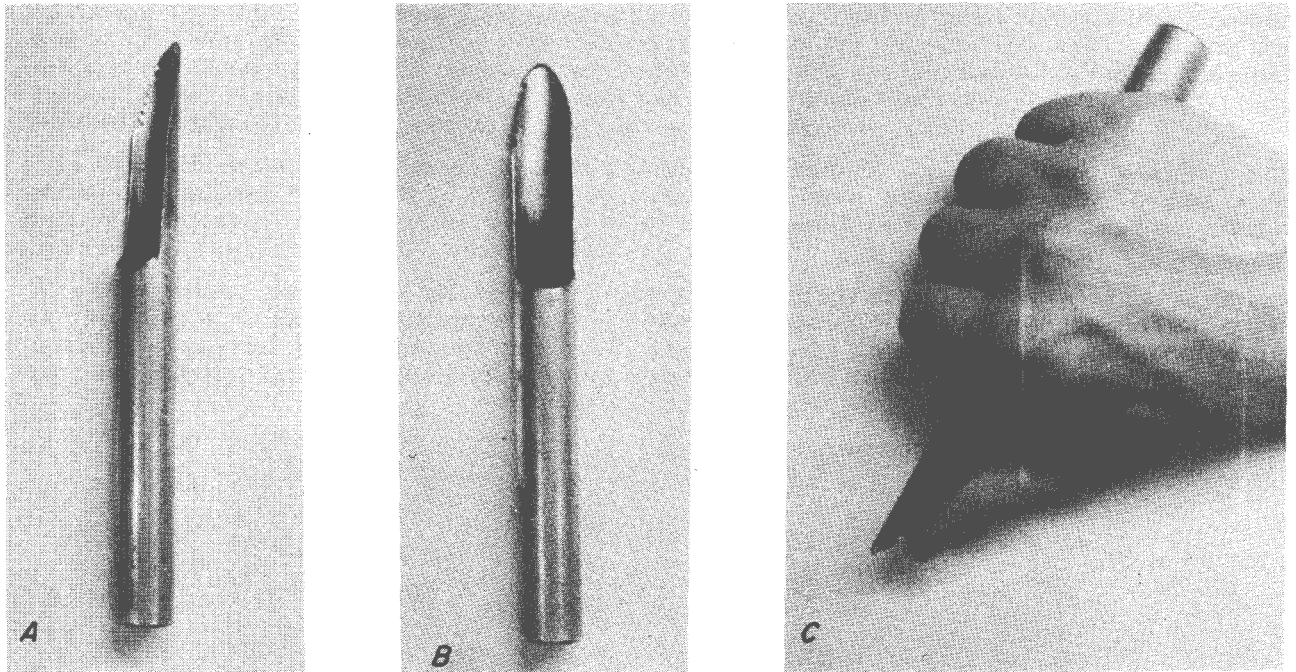

Figure 1.--The Ward weeder.

MIST SPRAYER IMPROVES SEEDLING HARVESTER

Gilbert H. Schubert, Karl B. Lanquist²

A new role has been assigned mist sprayers in California. For years vegetables have been kept crisp and fresh by spraying a fine mist of water over them. Now forest tree seedlings at the Mt. Shasta Nursery are given a similar refreshing treatment immediately after they are lifted from the nursery beds.

A nursery's reputation hinges on the success or failure of its trees to survive when field planted. The delicate roots of young seedlings are irreparably damaged when they lose all their moisture. To us the time interval between lifting and packing may seem short. But to tree roots without soil even this short exposure may be more than can be endured. The mist sprayer has solved the problem of keeping the roots moist.

The development of the "seedling harvester" greatly increased planting success in California. Before its development, lifting crews heeled-in seedlings in bunches of about 50 trees to keep them moist. These bunches were later packed in field crates by another crew. The seedling harvester eliminated the need for heeling-in and reduced the amount of handling. This improved the condition of the trees. However, on the original model³ trees were still exposed to the hot sun as they rode the conveyor. This deficiency was corrected by adding a shade frame over the conveyor.

Weather conditions during the fall lifting season in California are often dry and windy--excellent for drying clothes but extremely hard on young trees. Therefore an efficient method to keep the trees moist and fresh was needed--the answer, a mist sprayer.

The mist sprayer at Mt. Shasta Nursery was made from an old paint sprayer and is simple and easy to operate. Air pressure is supplied by an internal piston-type, gasoline-powered compressor, mounted on the back of the drawbar of the seedling harvester (fig. 1). The water tank, also mounted on the drawbar, holds about 20 gallons

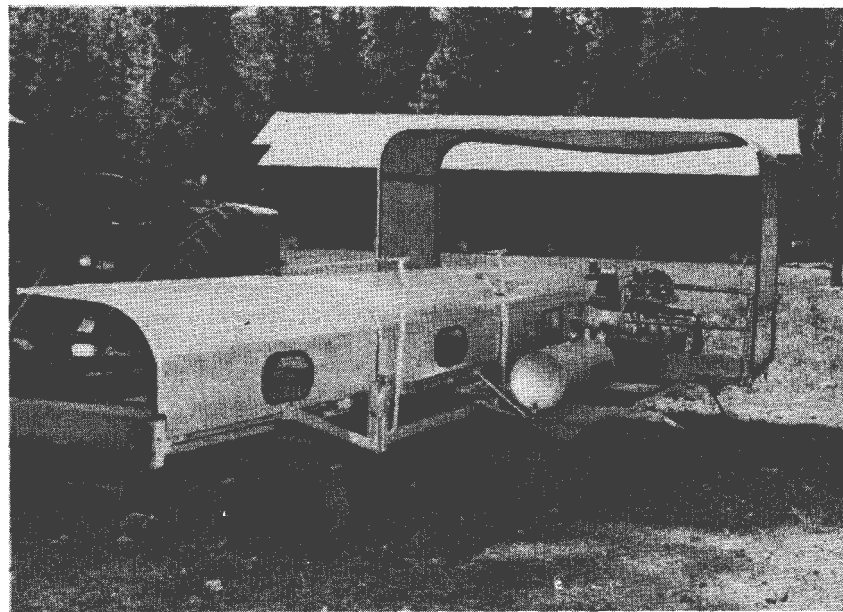

Figure 1: -Front view of seedling harvester showing location of compressor unit and water tank for the mist sprayer.

¹ Forester, Pacific Southwest Forest and Range Experiment Station, Berkeley, Calif.

² Nurseryman, Mt. Shasta Nursery, U.S. Forest Service, McCloud, Calif.

³ Lanquist, Karl B. Seedling Harvester. Tree Planters' Notes 16: 5-6. illus. 1954.

of water--enough for a 2- to 3-hour run. The mist system consists of a short piece of 1/2-inch pipe fitted with 6 mist nozzles (Whiteshowers type) (fig. 2). The spray is adjusted to moisten thoroughly the seedling roots without washing off the small soil particles clinging to the fine roots.

The small additional cost of the improved version of the seedling harvester should be returned many fold. Seedlings are kept in top condition and more suited to endure cold storage or shipment to planting sites.

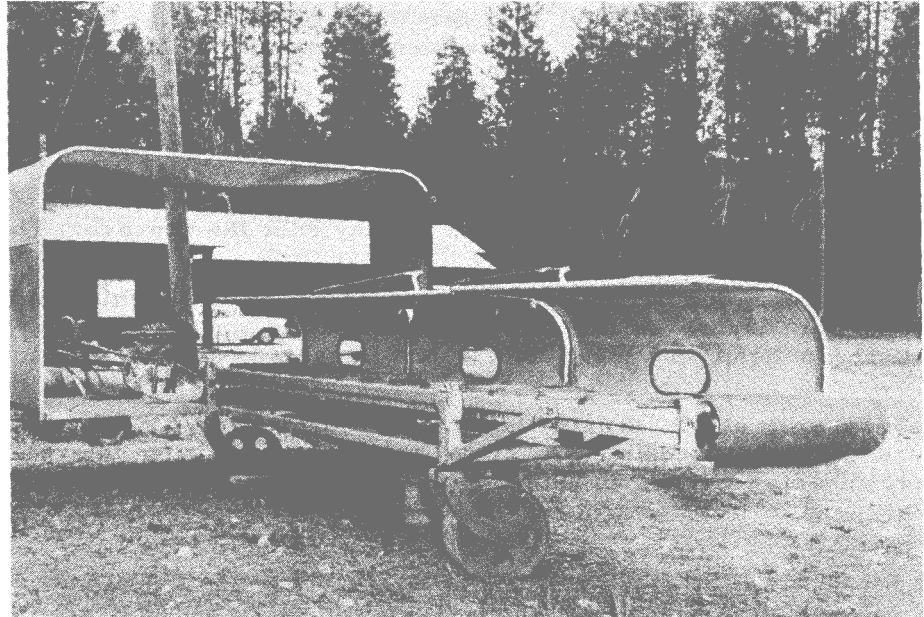

Figure 2.--Rear view of seedling harvester showing location of mist nozzles over the conveyor.

WOOD TREATED WITH PENTA CAN DAMAGE
PINE NURSERY SEEDLINGS

Edwin R. Ferguson
Nacogdoches Research Center¹
Southern Forest Experiment Station, U.S.F.S.
Nacogdoches, Texas

Wood treated with pentachlorophenol should be used with caution in pine seedling nurseries. During 1958 many freshly germinated pine seedlings died in experimental nurseries in Mississippi and Texas where the bedboards and screen frames were of preservative-treated wood. Damage was suspected to have been caused by the preservative, 5 percent pentachlorophenol in diesel oil.

Some of the wood had been treated 6 to 8 months previously, but ripped immediately before use; some had been treated for 6 months and allowed to weather in the open; and some had been freshly brush treated. Shortly after germination, damage was apparent in all nursery beds where treated wood had been used. Symptoms first appeared next to the wood, but spread rapidly across the 4-foot bed on all species except longleaf.

Since copper naphthenate had proved safe for greenhouse use with tomato plants, tests were made late in 1958 at the Austin Experimental Forest greenhouse, Nacogdoches, Texas, to compare toxicity to pine seedlings of this chemical and pentachlorophenol.

Sideboards for ten 24-inch square seed flats were cut from 1- by 4-inch pine boards. When the boards had been cut to length, the following treatments were applied:

1. Five-percent pentachlorophenol in diesel oil (three flats).
2. Copper naphthenate (2 percent metallic copper) in diesel oil (three flats).
3. Diesel oil (two flats).
4. Check--no treatment (two flats).

After cold-soaking for approximately 4 hours, the sideboards were assembled and allowed to weather in the open for 30 days. Then untreated plywood bottoms with drainage holes were nailed on each flat.

On November 4, all flats were filled with soil and placed on the floor in the center aisle of the greenhouse, according to a plan of randomization. Adjacent flats were spaced 2 feet apart. Flats were divided into quarters, and each quarter was sown with 100 seeds of one of the 4 major southern pines: all four species were represented in each flat. The flats were mulched with pine straw and watered according to normal greenhouse practices.

One month after sowing, more than 90 percent of all species had germinated. Damage was very apparent, on all species except longleaf, in those flats that had been treated with penta. The symptoms were needle twisting, followed by blanching and then desiccation.

¹ Maintained in cooperation with Stephen F. Austin State College, Nacogdoches, Texas.

² Kaufert, F. H., and K. A. Loerch. 1955. Treated lumber for greenhouse use.-Minn. Forestry Notes 36, 2 pp.

Two months after sowing, the flats treated with penta had fewer than 10 percent of slash, loblolly, or shortleaf seedlings alive, and some of the survivors showed injury, as follows:

	<u>Slash</u>		<u>Loblolly</u>		<u>Shortleaf</u>		<u>Longleaf</u>	
	<u>Killed</u> <u>(per-</u> <u>cent)</u>	<u>Injured</u> <u>(per-</u> <u>cent)</u>	<u>Killed</u> <u>(per-</u> <u>cent)</u>	<u>Injured</u> <u>(per-</u> <u>cent)</u>	<u>Killed</u> <u>(per-</u> <u>cent)</u>	<u>Injured</u> <u>(per-</u> <u>cent)</u>	<u>Killed</u> <u>(per-</u> <u>cent)</u>	<u>Injured</u> <u>(per-</u> <u>cent)</u>
Copper naphthenate - - - -	0	3	0	7	0	8	0	0
Diesel - - - - - - - - - - -	0	4	0	6	0	9	0	0
Penta - - - - - - - - - - -	86	8	94	5	90	9	0	50

Injuries from the copper naphthenate and the diesel oil were in single flats of each treatment. In each case, the flat was adjacent to and west of a penta-treated flat. The greenhouse is cooled by two exhaust fans in the east wall, and air movement is from east to west.

An additional test was installed in January 1959. Soil from the variously treated flats was removed and replaced in differently treated flats, so that soil from an untreated flat was moved to a treated flat and vice versa. Slash pine seed was sown, the flats were mulched, and routine greenhouse practices followed as before. Two months after sowing, mortality had occurred only in the flats that had been treated originally with penta, and in these flats averaged less than 50 percent. There was no evidence of damage from soil that had been exposed previously to penta-treated boards. This finding, together with evidence from the initial test, supports the premise that penta damage to seedlings is caused by volatile material diffused through the air.

The low mortality in the second test indicates that toxicity of penta-treated wood is reduced by a time lapse after treatment. More than a year after being soaked in penta, however, test bedboards in the Austin Experimental Forest nursery harmed some germinating loblolly seedlings.

Unless local trials have shown how much time is required to eliminate harmful effects, penta-treated materials should be avoided in greenhouses or tree nurseries. Even then the minimum safe weathering period will apply only to material cut to size before weathering, not to material cut up after weathering. If preservative is needed for wood that will be close to freshly germinated southern pine seedlings, either in a nursery or in a greenhouse, a good choice might be 0.2 percent metallic copper solution of copper naphthenate in either diesel oil or one of the other lighter hydrocarbons.

LATERAL ROOT PRUNER

Hugh B. Wycoff
Nursery Superintendent, Mason State Tree Nursery
Topeka, Ill.

Root pruners have been used effectively in pruning the lateral roots of seedlings planted in rows. Although common in many nurseries, they have certain disadvantages. At Mason State Tree Nursery we have made some modifications of this general method and now have a pruner we believe is more effective.

The root pruner is mounted on the back of a wheeled tractor by means of a common 3-point hydraulic lift. It is built on a cultivator frame with the shank clamps staggered at 6-inch spacing. Nine 18-inch rolling coulters were mounted on the frame in place of the cultivator shanks (fig. 1). A vertical guide rod on the front axle is necessary to keep the coulters in position between the tree rows. Stabilizer braces are used on the cultivator.

The staggered arrangement of the coulters is much better than having them in a straight line, since there is less soil compression and lifting action. The swivels on the coulters permit changing direction with less soil disturbance and stress on the coulters.

We undercut the beds at a depth of 4 to 6 inches with a horizontal tree lifter blade without tines before using the lateral root pruner. The root systems are pruned on three sides.

The cuts remain distinct for a year. Clumps of seedlings can be lifted easily at any time for root inspection and replaced.

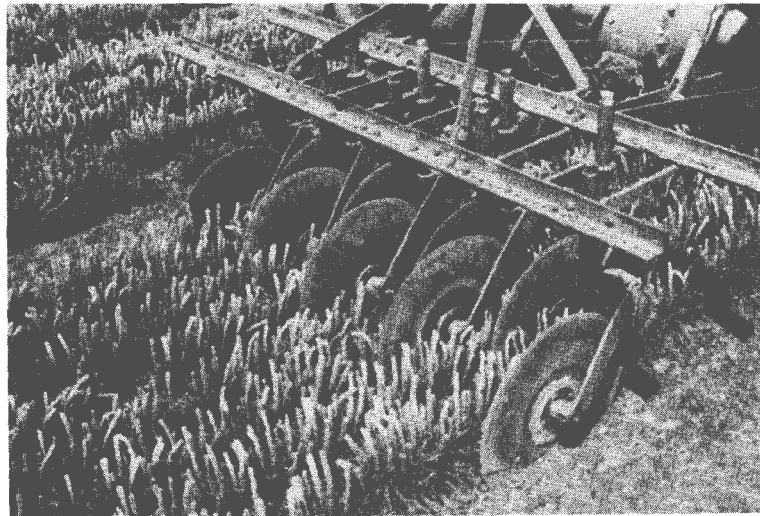

Figure 1.--Lateral root pruner with staggered arrangement of coulters.

CAUTION NEEDED IN FALL APPLICATIONS
OF NITROGEN TO NURSERY STOCK

Eugene Shoulders

Alexandria Research Center
Southern Forest Experiment Station, U.S.F.S.
Alexandria, La.

Late-season fertilization of nursery beds with heavy applications of nitrogen is sometimes suggested as a way to improve field survival of southern pine seedlings. A study conducted in 1956 and 1957 by the Alexandria Research Center of the Southern Forest Experiment Station showed that the practice is not an easy, sure cure. While it may be helpful in some circumstances, it must be used with extreme caution, for it can also depress survival.

Related Work

Commercial fertilizers are usually applied before the beds are sown or added as topdressings while the seedlings are growing rapidly. The two methods are often combined to ensure an adequate supply of nutrients through the season.

Early results¹ of studies at North Carolina State College indicated that fertilization of normal and yellow longleaf and loblolly seedlings with ammonium nitrate at a rate of 160 pounds of actual nitrogen per acre at least 3, and preferably 5, weeks before lifting would improve survival of the outplanted seedlings.

An exploratory study by the Alexandria Research Center, in which normal loblolly and slash pine seedlings were topdressed with 160 and 200 pounds of nitrogen per acre 5 weeks before lifting, failed to confirm these results: fertilized and unfertilized seedlings survived equally well.

Ursic² depressed survival of normal loblolly seedlings by topdressing the nursery beds with 160 pounds of nitrogen plus 200 pounds of K₂O per acre 1 month before lifting.

Study Methods

The study reported here was conducted in the Northwest and Southwest Nurseries of the Louisiana Forestry Commission. Beds were seeded to longleaf, loblolly, and slash pines on March 28, 29, and 30, 1956. In May, after germination was complete, longleaf pine beds were thinned to 25 to 30 seedlings per square foot, and loblolly and slash pine beds to 35 to 40 seedlings. Otherwise, the seedlings received normal nursery fertilization and care until topdressings were applied in mid-December.

Before the December fertilization, the beds of each species in each nursery were divided into nine 9-foot segments, with buffer strips between. Treatments included the application of ammonium nitrate at the rates of 150 and 300 pounds of actual nitrogen per acre and an unfertilized check. The fertilizers were divided into three equal parts and applied during a Z-week period to prevent burning of the seedlings. Each treatment was replicated 3 times in a randomized block design.

After treatment, the seedlings remained in the beds for about 8 weeks before they were lifted and planted in February 1957. Stock from the 3 plots of each fertilizer treatment was composited and representative samples of morphological grade 1 and 2 seedlings,³ combined, were accepted for planting.

Six randomized blocks were established on each of two sites. Each block contained all possible combinations of three species, two nurseries, and three fertilizer treatments. Plots were rows of 25 trees.

¹ Unpublished data.

²Ursic, S. J. Late winter prelifting fertilization of loblolly seedbeds. U.S. Forest Serv. Tree Planters' Notes 26, pp. 11-13. 1956.

³Wakeley, P. C. Planting the southern pines. U.S. Dept. Agr., Agr. Monog. 18, p. 103. 1954.

Results

The topdressing induced growth of seedlings in the nursery beds during the mild winter of 1956-57, and by lifting time many of the buds had burst. Stems had not elongated, however, and topdressing did not affect the size of plantable seedlings (table 1). Unfertilized trees remained dormant.

Survival of longleaf and loblolly seedlings from the Southwest Nursery was substantially depressed by fertilization, and the highest rate reduced field survival the most (table 2). Survival of slash pine seedlings grown in adjacent beds was not significantly affected.

All stock from the Northwest Nursery benefited from topdressing, but the species differed in the amount of additional nitrogen needed to improve survival. In some instances, the addition of more or less than the optimum amount produced lower survival than no fertilization. Loblolly seedlings were not affected by the addition of 150 pounds

TABLE 1.--Average size of planting stock at lifting time

Nursery	Actual N applied per acre as top-dressing	Loblolly		Longleaf		Slash	
		Root collar diameter	Height ¹	Root collar diameter	Height ¹	Root collar diameter	Height ¹
	<i>Pounds</i>	<i>Inches</i>	<i>Inches</i>	<i>Inches</i>	<i>Inches</i>	<i>Inches</i>	<i>Inches</i>
Northwest-----	0	5/32	9	10/32	12	6/32	6
	150	6/32	9	10/32	11	5/32	7
	300	6/32	8	11/32	12	7/32	6
Southwest-----	0	5/32	9	10/32	13	5/32	8
	150	5/32	9	12/32	13	5/32	8
	300	5/32	9	11/32	14	5/32	8

¹ Height from root collar to base of terminal bud or tuft of needles for loblolly and slash pine. Length of needles for longleaf pine.

TABLE 2.--How late-season topdressing with ammonium nitrate affected first-year survival of pine seedlings from two Louisiana nurseries

Nursery	Actual N applied per acre	First-year survival of--		
		Longleaf	Loblolly	Slash
	<i>Pounds</i>	<i>Percent</i>	<i>Percent</i>	<i>Percent</i>
Northwest-----	0	88	74	88
	150	95	74	85
	300	86	88	94
	Average	90	79	89
Southwest-----	0	36	79	56
	150	32	69	58
	300	20	60	63
	Average	29	69	59

of nitrogen per acre, but application of 300 pounds of nitrogen per acre increased survival to 88 percent--as contrasted with 74 percent for unfertilized stock.

Slash pine also responded to fertilization at the highest rate, but the increase in survival was smaller. When slash was fertilized at a rate of 150 pounds of nitrogen per acre, survival was slightly lower than that of untreated stock. With longleaf pine, seedlings topdressed at the 150-pound rate survived best.

Seedlings from the Northwest Nursery survived better than those from the Southwest Nursery in almost all instances. These seedlings of apparently superior vigor were improved by winter topdressing with nitrogen. In contrast, less vigorous seedlings from the Southwest Nursery were harmed or unaffected by fertilization.

Conclusions

This study further demonstrates the folly of prescribing fertilization without adequate knowledge of the needs of the plant at the particular time the fertilizer is to be available, and the extent to which these needs will be supplied by nutrients already in the soil.

More specifically, in tests at widely separated nurseries at different times, fall applications of nitrogen to beds of normal seedlings have improved survival, produced no response, and decreased survival. Both increases and decreases in survival associated with the treatments have been substantial.

It may be concluded that post-growing-season fertilization with nitrogen is useful when nutritional levels indicate it is needed, but that wholesale applications may be more damaging than the condition they are supposed to cure. Therefore, the practice should be employed only where there is a demonstrated need.

As knowledge of seedling nutrition increases, it may be possible to analyze soil samples from compartments or even individual beds, and thus determine where late-season fertilization is needed. Meanwhile, small empirical tests in individual nurseries should help nurserymen determine areas where the practice is useful.