

JERRY L. EDWARDS 2/

Abstract.--The expansion of the containerized seedling program has generated the need for new and better planting equipment both hand and machine types. To meet this growing need the existing bare root planting equipment is being modified and new equipment developed. This article covers the state of the art in containerized seedling tree planting.

INTRODUCTION

The rapid increase during the last ten to fifteen years in the containerized seedling programs have resulted in a need for mechanization in tree planters suited to the containerized planting stock. Hand planting tools have been developed to meet the varying needs of container types and planting conditions. However, the hand planting is labor intensive and extremely costly. In many areas this is the only means possible to accomplish the out-planting due to soil type and terrain. In some areas and especially the Southeastern states a machine planter is needed and will work most effectively to plant the thousands of acres of timber land needing regeneration each year. Several of the existing bare root mechanical tree planters have been used with relative success to plant containerized stock. To date there is no mechanized planter available commercially which has been designed expressly to accommodate containerized planting stock. Presently there is one prototype under construction and two other proposals being considered. The purpose of this paper is to discuss design considerations and hardware when mechanizing container planting.

HAND PLANTERS

The development of hand operated tree planters for container stock is directly

1/Paper presented at North American Containerized Forest Tree Seedling Symposium, Denver, Colorado, August 26-29, 1974.

2/Mechanical Engineer, Southern Region, USDA Forest Service, 1720 Peachtree Road, N.W., Atlanta, Georgia 30309.

related to the particular container type and the localized planting conditions. The soil type in the area has the largest single effect on the planter configuration followed by the soil moisture content of the soil. Nearly all the planters will operate effectively in the mid-range soil types (sandy loam, loam, and clay loam). However, they must be especially designed and adapted to work in the sand and clay type soils. A tool used in clay type soil must be designed to insure against soil compression or case hardening of the sidewalls during hole opening and then insure during closure that the soil returns about the container leaving no air voids. On the other hand sandy soil presents the opposite problem in that the tool must prevent the sidewalls from caving in until after the container has been placed in the hole. (See Table I). The hand planters can be placed in two basic categories, Displacement and Augers.

TYPE I Displacement - Hand held, shaft mounted soil displacement end bit (See figure 1).

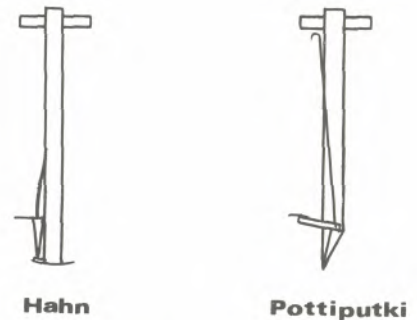

Figure 1 (continued on p. 270).

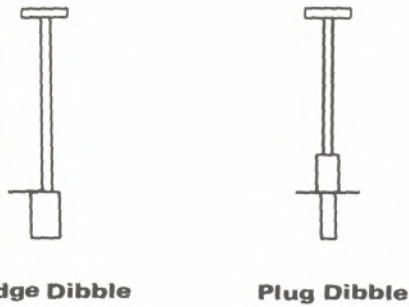

Figure 1. (continued)

TYPE II Auger - Hand guided, powered by a gasoline engine with speed reduction device and soil auger bit (See figure 2).

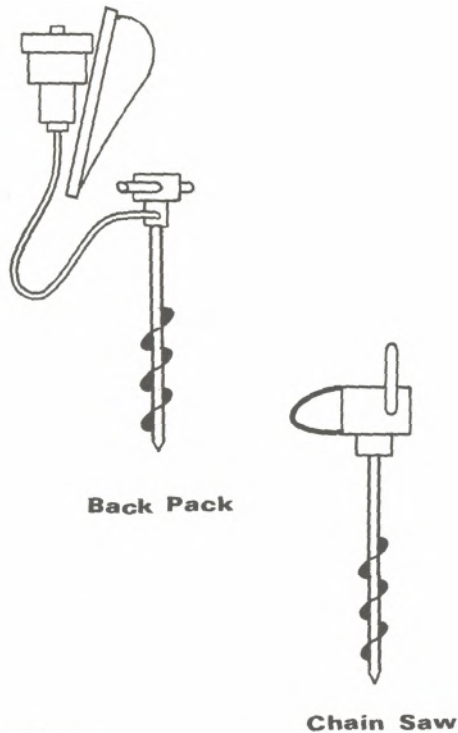

Figure 2---

PLANTING MACHINES

The conventional mechanical tree planters which were initially designed for bare root planting stock are now being utilized for planting container stock, in most cases this conversion required only minimal modification. Soil type and moisture content affects the mechanical planters to the same degree as it does for hand planting tools. Mechanical planters can be grouped into two categories; Continuous Furrow and Intermittent.

CATEGORY I Continuous Furrow

Type 1---Mechanically limited planting depth with hand (or planting finger*) seedling placement and spacing in the furrow. (See Fig. 3)

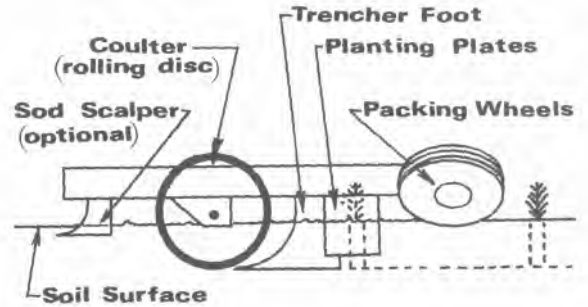

*Forestland tree planter only
Figure 3.---

Type 2---Mechanically limited planting depth with hand placement and selected spacing within the row. Wedge type furrow opening coulter. (See figure 4)

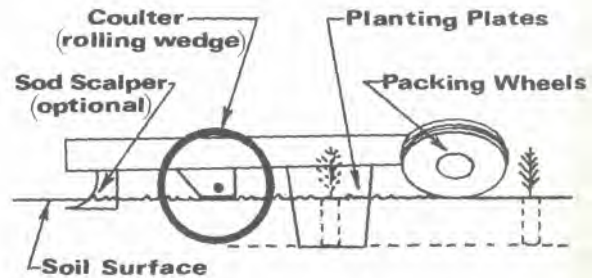

Figure 4---

Type 3---Mechanically limited planting depth with hand placement and selected spacing within the row, Wedge type furrow opening coulter and offset rolling disc furrow closure. (See figure 5).

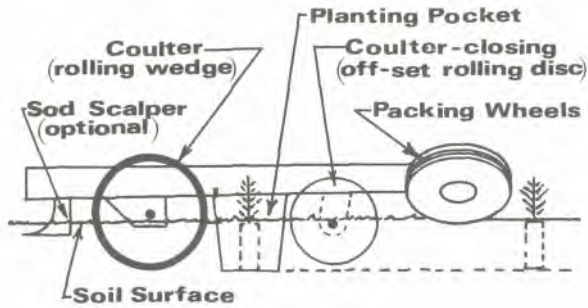

Figure 5---

CATEGORY II Intermittent

Type 4---Semi-automatic planting with mechanically limited planting depth and operator/mechanically selected spacing within the row, hydraulically operated packing wheels. (See figure 6)

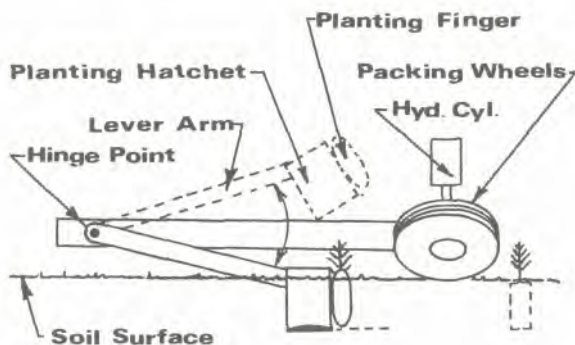

Figure 6---

(See TABLE II for additional details)

AUTOMATED TREE PLANTER

The design of an automated tree planter utilizing the containerized planting stock presents several problems for the designer. The first, and probably the most perplexing, is the container itself. In a search for the perfect container there has been a multitude of containers made available. This condition of variation in container shapes, sizes, and types make it practically impossible for a designer to select one particular design configuration which will allow a planting machine to accommodate all of the containers. The

types of containers being used in the volume production of seedling can be placed in two general categories, Extractable Plugs and Container Plantable.

Extractable Plugs---present several problems to a mechanized tree planter in that the plug itself must either be extracted from the growing container at the growing site and placed in special containers before being placed on the planting machine so as to be easily handled by the machine or a special mechanical device must be developed which will select an individual plug and extract it from the growing container and then feed this plug on through the planting mechanism. Evaluation of these two materials handling problems as they relate to a wild-land tree planting led to the conclusion that a mechanism sophisticated enough to accomplish the job would be much too costly and highly susceptible to damage. For this reason the extractable plugs were not selected for use with an automated tree planter.

Container Plantables---lend themselves more easily to a mechanized planting system since the entire unit can be placed in the ground. In most cases these containers are loose and not interconnected in any way resulting in a difficult item for mechanical systems to handle under the rough field conditions. In an effort to facilitate the design of mechanical feed system the manufacturers of the different container plantable types that had shown promise in producing a viable seedling were contacted and requested to submit proposals as to how they could best form their container into a continuous belt of containers (similar to a machine gun belt). Initially the only company which expressed any particular interest in this aspect of the project was the Japanese Paperpot manufacturer. Since that time several other companies have shown interest. The Japanese Paperpot manufacturer has supplied samples of a belted container which will be used for the prototype development of the tree planter.

Design Criteria

General

The tree planter is an implement for precision, fully automatic, intermittent planting of containerized seedling stock of conifers and other species at a selected depth and spacing along a prescribed row. It will be suited for planting on irregular topography side slopes up to 15% and vertical slopes up to 30% while attached to a prime mover. Soil types range from sand to clay; also, these soil types may have varying amounts of rocks, roots, and logging debris.

The feed and planting mechanisms will be modularly designed to permit interchangeability for different container types and soil conditions.

Container

Size - diameter range 3/4" to 1 1/4" (Prototype nominally - 1")

Length - 3 1/2" to 8" (Prototype-nominally 6+1/2")

Plant height above container - 3" to 6"

Shape - square, round, triangular, and hexagonal (Prototype - hexagonal-belted)

Skin - hard (plastic) to soft tissueous membrane (Prototype - tissueous membrane)

Rate of Travel - 0 to 2.5 mph. \pm 10%

Rate of Planting - fully automatic 1200 trees per hour at 2.5 mph)

Tree Spacing -

Space between trees in row - 10 to 15 feet (infinitely variable)

Space between rows - 10 to 15 feet

Row width - maximum 1 foot each side of row centerline

Tree Attitude at Planting Site

Planting depth - 3" to 8" container to be placed with top of media flush with ground (Prototype nominally 5 1/2 + 1/2")

Angle of tree in ground - \pm 15⁰ from gravity vertical

Quantity of Trees Carried on Planter - 1 hours planting supply (Approximately 1500 trees)

Quantity of Trees Per Planting Spot - 1 container

Soil Surrounding Container (micro environment)

Soil Condition - uniformly firm in contact with periphery of container (air voids along sides or bottom, not to exceed 0.5 sq. in. in any one area). Side walls of hole in contact with container not to be case or work hardened to a density greater than 1-1/2 times that of original condition.

Site Treatment - no more than 6 inches in any direction from the container location shall be disturbed during the entire planting operation.

Meteorological Operations Requirements - The planting machine must operate under the same conditions as the prime-mover. (rain, snow and temperatures 30 - 115° F)

Failure to Penetrate Soil - The implement will fully recycle (maximum loss one additional cycle).

Planting Head - Different heads are permissible for different soil types, or container length, and planting depth; however, changeover time from one head to another must be accomplished in less than 30 minutes by one man under field conditions.

Prime Movers - Ultimately the tree planter may be attached to any of the following type and sizes of equipment:

Size and Type - Crawler tractors (Cat. D-4)

- Wheel skidder (Pettibone-501)

- Agricultural Wheel Tractor (IHC-656)

Prime Mover to be Used With Prototype - The implement will be attached to a Caterpillar D-4 crawler tractor with a A.D.C. hitch.

Implement ground clearance - equal to that of the prime mover (12" min) Angle of Departure - 30⁰ \pm 5% during transportation.

Width - not greater than that of the prime mover (8 feet)

Drawbar - 35,000 lbs. maximum

Hydraulic Supply - 34 GPM at 1,725 PSI

Implement Attachment Time - Connect or disconnect by one man in less than 3 minutes under field conditions without having to dismount from the operator's seat.

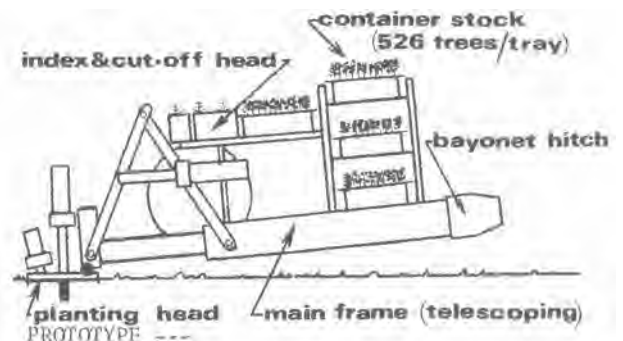

TABLE I

HAND PLANTER

Name	TYPE I	TYPE II	SOIL TYPE IMPLEMENT IS BEST SUITED TO...
CANNON		X	SL, L, CL, & C
HAHN	X		SL, L, & CL
HAYNES		X	SL, L, CL, & C
LITTLE BEAVER		X	SL, L, CL, & C
McCULLOCH		X	SL, L, CL, & C
MOTOR MOLE		X	SL, L, & CL
POTTIPUTKI	X		S, SL, & L
WEDGE DIBBLE	X		SL, L, CL, & C

S-SAND SL-SANDY LOAM L-LOAM CL-CLAY LOAM C-CLAY

TABLE II

MECHANICAL PLANTER

Name	CAT. I			CAT. II	SOIL TYPE, IMPLEMENT IS BEST SUITED TO...
	Type-1	Type-2	Type-3	Type-4	
FORESTER	X				S, SL, & L
FORESTLAND	X				S, SL, L, & CL
HUGHES			X		S, SL, L, & CL
ONTARIO (WEY.)				X	S, SL, L, & CL
REYNOLDS-LOWTHER--- DUAL COULTER			X		S, SL, L, CL, & C
CRANK AXLE		X			S, SL, L, & CL
ROCKY MT.	X				SL, L, & CL
TAYLOR--- MODEL 16	X				S, SL, L, & CL
MODEL 44D & 60D		X			S, SL, L, & CL
TIMBER CAT	X				S & SL

S-SAND SL-SANDY LOAM L-LOAM CL-CLAY LOAM C-CLAY

MANUFACTURERS LIST

Hand Planters

Forestry Suppliers Inc.
Box 8397
Jackson, Miss. 39204
(ledge Dibble)

Haynes Manufacturing Co.
P. O. Box 191
Livington, Tex. 77351
(Back Pack Auger)

Lannen Sokeri OY
27820 Lansi-SaKyla, Finland
(Motor Mole)

Master Grower
P. O. Box 47249
Atlanta, Ga. 30340
(Pottiputki)

Ben Meadows Company
553 Amsterdam Ave., N.E.
Atlanta, Ga. 30306
(Little Beaver)

McCulloch Corporation
6101 West Century Blvd.
Los Angeles, Calif. 90045
(McCulloch Auger)

Timberland Distributors Inc.
P.O. Box 22112
Portland, Ore. 97222
(Cannon Auger)

Tri-State Will Supply
P.O. Box 220
Crossett, Ark. 71635
(Hahn Quick-Dibble)

Mechanical Planters

Forest Equipment Co., Inc.
P.O. Box 245
Waycross, Ga. 31501
(Timber Cat)

Hughes Brothers
P.O. Box 191
Seward, Nebr. 68434
(Hughes)

David Mudie Co.
60 Advance Rd.
Toronto, Ontario, Canada 570
(Ontario-WEY)

Reynolds Research & Manufacturing Corp.
P.O. Box 550
McAllen, Tex. 78501
(Reynolds-Lowther)

Taylor Machine Works Inc.
Box 150
Louisville, Miss. 39339
(Taylor)

Utility Tool & Body Company, Inc.
151 East 16th Street
Clintonville, Wisc. 54929
(Forester)

R. A. Whitfield Manufacturing Co.
6411 Gordon Road
Mableton, Ga. 30059
(Forestland)

Lenard Young Corporation
8206 Fairview Avenue
Boise, Id. 83704
(Rocky Mt.)