

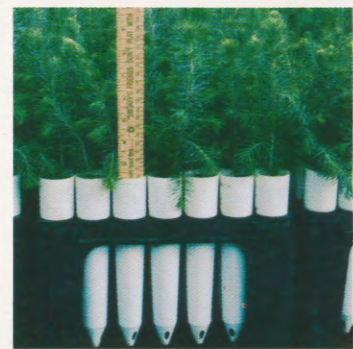

# Nursery Planning, Development, and Management





# **The Container Tree Nursery Manual**

## **Volume One Nursery Planning, Development, and Management**

### Chapter 4 Environmental Controls and Seedling Production Equipment

## Contents

<b>1.4.1</b>	<b>Introduction</b>	<b>101</b>		
<b>1.4.2</b>	<b>Environmental Controls and Instrumentation</b>	<b>102</b>		
1.4.2.1	Temperature	102		
	Cooling	102		
	Heating	104		
	Temperature sensors and controls		105	
	Heat conservation systems		106	
1.4.2.2	Humidity	106		
	Humidification	106		
	Dehumidification	106		
	Humidity sensors and controls		107	
1.4.2.3	Light	107		
	Shading	107		
	Artificial lighting	108		
	Light sensors and controls		108	
1.4.2.4	Carbon dioxide	109		
	Increasing carbon dioxide		109	
	Carbon dioxide sensors and controls		109	
1.4.2.5	Irrigation	109		
	Irrigation systems	109		
	Monitoring and regulating irrigation		110	
1.4.2.6	Fertilization	110		
	Fertilization systems	110		
	Monitoring and regulating fertilization		113	
1.4.2.7	Environmental control systems		113	
	Discrete and dedicated controls		113	
	Analog and integrated controllers	113		
	Climate control computers	113		
1.4.2.8	Nursery security and emergency equipment		115	
<b>1.4.3</b>	<b>Benches and Supports for Containers</b>	<b>118</b>		
1.4.3.1	Pallets	120		
1.4.3.2	Benches	120		
	Stationary benches	120		
	Movable benches	121		
1.4.3.3	Construction materials	122		
<b>1.4.4</b>	<b>Handling Equipment for Materials and Seedlings</b>	<b>125</b>		
1.4.4.1	Conveyors	126		
1.4.4.2	Hand carts and motor vehicles	128		
<b>1.4.5</b>	<b>Seedling Production Equipment and Supplies</b>	<b>129</b>		
1.4.5.1	Containers	129		
	Types of containers	129		
	Cleaning and sterilizing used containers		130	
1.4.5.2	Artificial growing media	132		
	Components	132		
	Mixing growing media	132		
1.4.5.3	Sowing lines	135		
1.4.5.4	Container filling equipment	136		
1.4.5.5	Sowing equipment	138		
	Shutterbox seeders	138		
	Vacuum plate seeders	139		
	Automated and precision seeders		141	
	Seed mulching (gritting)	141		
1.4.5.6	Transplanting equipment	144		
1.4.5.7	Pesticide application equipment		144	
	Portable sprayers	145		
	Boom sprayers	145		
<b>1.4.6</b>	<b>Seedling Harvesting Equipment</b>	<b>146</b>		
1.4.6.1	Grading and packing lines	148		
1.4.6.2	Storage	149		
<b>1.4.7</b>	<b>Summary</b>	<b>150</b>		
<b>1.4.8</b>	<b>Literature Cited</b>	<b>151</b>		

## 1.4. 1 Introduction

In chapter 3 of this volume, we designed a propagation environment that is suited to both the climate on the site and the biological requirements of the crop. Now, in this chapter, we will discuss some of the equipment and materials that are needed to maintain that environment and produce a crop of seedlings.

This chapter consists of two general parts. The first part (section 1.4.2) briefly discusses the types of equipment that can be used to modify the propagation environment to optimize the **six factors limiting to seedling growth: temperature, humidity, light, carbon dioxide, water, and mineral nutrients**. This section is intended as a general introduction for nursery developers who are designing new nurseries as well as nursery managers wanting to upgrade their existing facilities. (More specific information on the biophysical concepts of the limiting factors, how to modify each factor, and monitoring and control systems are given in volumes three and four of this series.)

The second part of this chapter (sections 1.4.3 to 1.4.6) deals with the materials and equipment needed to produce a crop of seedlings, from the types of benches to kinds of storage systems. A short discussion of the basic concepts introduces each step in the seedling production process. (More details are provided in volumes two, six, and seven of this series. Volumes six and seven are still in preparation at this time.)

## 1.4.2 Environmental Controls and Instrumentation

Seedlings raised in open growing compounds can be supplied with irrigation and fertilization, and light and temperature can be controlled to a minor degree. Container nurseries that grow their seedlings in some sort of a propagation structure have the potential to control all 6 limiting factors. The degree of control depends on the type of structure and the environmental control equipment that is provided. For planning purposes, most equipment costs vary with the size of the propagation area, although some are fixed costs (table 1.4.1).

### 1.4.2.1 Temperature

The options for temperature control in open compounds are very limited. Shelterhouses or greenhouses are generally equipped with heating and cooling equipment that correspond to the type of structure and the nursery climate.

**Cooling.** The only form of temperature control possible in open growing compounds is cooling with irrigation. This technique can also be used in propagation struc-

**Table 1.4.1—Planning cost estimates for environmental control equipment**

Environmental factor & type of equipment	Cost/m <sup>2</sup>	Cost/ft <sup>2</sup>
<b>Temperature—cooling</b>		
Exhaust fans and controls	\$ 8.61–12.91	\$0.80–1.20
Evaporative cooling system	15.06–19.37	1.40–1.80
Automatic shade curtain (also in light section)	17.22–25.82	1.60–2.40
<b>Temperature—heating</b>		
Unit heaters—warm air	10.76–18.83	1.00–1.75
Central heater—hot water or steam	16.14–26.90	1.50–2.50
Heat retention system—manual	5.38–10.76	0.50–1.00
Heat retention system—motorized	13.45–32.28	1.25–3.00
<b>Water/humidity</b>		
Fixed overhead sprinklers	8.07–13.45	0.75–1.25
Travelling boom sprinkler*	10.76–21.52	1.00–2.00*
Fog system	5.38–10.76	0.50–1.00
<b>Mineral nutrition</b>		
Fertilizer injector*	1.61– 5.38	0.15–0.50*
<b>Light</b>		
Photosynthetic lighting system	21.52–26.90	2.00–2.50
Photoperiodic lighting system	10.76–32.28	1.00–3.00
Automatic shade curtain (also in cooling section)	17.22–25.82	1.60–2.40
<b>Carbon dioxide</b>		
Carbon dioxide generator	1.08– 2.15	0.10–0.20
<b>All</b>		
Environmental control computer*	8.07–13.45	0.25–1.25

Note that these are only equipment costs; operating costs can be substantial.

\* More or less fixed costs, which vary only slightly with number of zones.

Source: Aldrich and Bortek (1989); Murrett (1992); MacKenzie (1992).

tures. Because any surface, including foliage, from which water evaporates is cooled, short bursts of irrigation will lower the temperature of the seedling without raising the soil moisture to harmful levels.

Temperature control becomes much more complicated in propagation structures because of solar heating. During the day, it is often more difficult to cool a greenhouse than it is to heat one because many wavelengths of sunlight are converted to heat energy and the covering stops air exchange. A recent study found that half of the solar energy entering a greenhouse on a bright sunny day increases the air temperature (Roberts and Giacomelli 1992).

Modifying the propagation structure is the first cooling strategy. Shelterhouses are popular because the sides can be raised to allow natural ventilation (see fig. 1.3.5A). With established greenhouses, shading should be considered if the crop can grow well at lower light intensities. Some forest and conservation species can grow reasonably well at lower light intensities but many, including most of the commercial conifers, do not. Of course this depends on regional climate. In the Intermountain West, sunlight intensities are generally high, so shading should be considered. In climates with many days of cloudy weather, however, further reduction in light intensity may not be acceptable. Automatic shade curtains are relatively expensive (fig. 1.4.1 A), but they do give the grower good control over light intensity in the propagation area. (Seedling shade tolerance is discussed in volume three, pages 80-82 and shading techniques, pages 28-29.)

Cooling equipment operates on two biophysical principles: first, increasing air flow replaces warm air in the boundary layer around the seedling and second, a

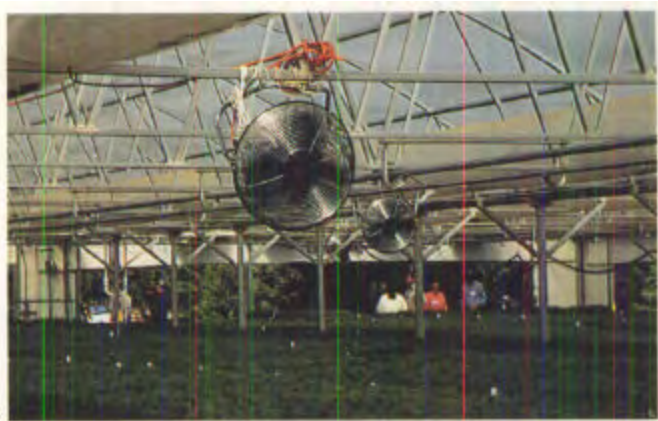

B



C



A

**Figure 1.4.1**—Propagation environments can be cooled by reducing sunlight with shade cloth (A), increasing horizontal air circulation with fans (B), or with evaporative cooling by drawing air through a wet wall (C).

substantial amount of latent heat is absorbed when water evaporates. There are three types of cooling systems, which may be used singly but more typically in combination. Equipment costs vary with the type of system (table 1.4.1). (Cooling equipment is covered in volume three, pages 22-30).

**Convection ventilation.** This energy-efficient type of cooling relies on vents at the top and sides of the propagation structure. When the vents are open, hot air escapes out the top and draws in cooler and drier air from the sides. Vents can be opened manually or more commonly as the first stage in a sequential control system. Unfortunately, convection ventilation occurs best during colder weather when there is a strong gradient between inside and outside temperatures, and it is also dependent on the direction and speed of the wind (Roberts and Giacomelli 1992).

**Fan ventilation.** Fan ventilation is more reliable and efficient than convection cooling, and fully controlled propagation structures usually have one wall of exhaust fans to draw the air through them. Exhaust fan systems work best in structures under 45 m (150 ft) in length and must be properly sized and installed for optimum efficiency (Bartok 1993). Even shelterhouses are often equipped with portable fans to increase air exchange (fig. 1.4.1 B). The new horizontal air flow (HAF) systems can maintain air temperatures within 1.8 °C (2 °F) with as few as 4 circulating fans per structure (Bartok 1994).

**Evaporative cooling.** Fully controlled houses can also be equipped with evaporative cooling systems, but their efficiency depends on the climate. The drier the ambient air, the greater the cooling potential. Fans draw the intake air through a porous medium called a wet wall, which is kept wet with water from a recirculation tank (fig. 1.4.1 C). Efficient systems can cool the intake air to quite close to the wet bulb temperature. Most wet walls consist of vertical pads and require a recirculation tank and pump to keep them wet, but there are also horizontal pad systems that are sprayed and require no recirculation tank. Alternatively, fog nozzles can be installed at the air intake, allowing evaporative cooling to occur for some distance into the greenhouse.

**Heating.** The first principle of heating is to control the movement of heat, which moves by mass flow, conduction, and radiation. Control of mass flow means having a tight greenhouse, so that air enters and leaves the greenhouse only when and where it is supposed to. Conduction is retarded by insulation, and double-layer

coverings can greatly retard heat loss. The second principle is to add or subtract heat to maintain the desired temperature. The sun is a major source of heat that can be captured and stored in a shelterhouse with the sides lowered or a totally enclosed greenhouse. The thermal mass, or heat-storing capacity, will be greatest when the propagation structure is full. Because of the high latent heat of evaporation, irrigation practices must be considered in heating calculations.

Propagation structures can be warmed by two basic types of heating systems that differ in location and method of heat distribution. **Central heating systems** use large boilers that are located in the headhouse or in a separate structure and pump steam or hot water through pipes to a range of houses. Although they use a variety of different fuels and heat distribution techniques, **unit heaters** are used to heat individual propagation structures. (Heaters, fuels, and heat distribution systems are discussed in volume three, pages 30-36.)

**Steam or hot water heaters.** Generally associated with large central heating systems, these heaters distribute hot water or steam through plain or finned pipes that are located around the baseboard perimeter of the propagation structure or under the benches (fig. 1.4.2A). The pipes radiate heat, which then circulates through the propagation structure by convection. Baseboard heating eliminates cold air flow next to walls and is best suited to fully controlled greenhouses where the sidewall does not open. Because baseboard systems lose their effectiveness with increasing greenhouse width, they are better for single structures rather than for gutter-connected ranges. Under-bench heating pipes are beneficial for plant growth but impede access and are more expensive.

Hot water pipes can also be laid in an insulated concrete floor. Because the greenhouse floor acts as a heat reservoir, floor heating systems are most beneficial when plants are grown directly on low pallets. However, floor heating systems can be expensive to install and cannot react quickly to heat demand or to a change in desired temperature.

**Forced air heaters.** Because they are relatively inexpensive and easy to install, forced air heaters are popular for shelterhouses or individual greenhouses (fig. 1.4.2B). They also have a quick response time. Direct-fired forced air heaters can use a variety of fuels or they can receive hot water or steam from a central boiler. They are often connected to a fan-jet circulation system,

which distributes hot air through large perforated tubes. Forced-air heaters are often mounted overhead but this is inefficient because hot air rises. Although they hinder material handling, heat distribution tubes situated under the benches warm the root systems and generate better convective heat distribution. Moving air up through the seedling foliage also reduces disease problems.

**Infrared heaters.** These unit heaters are iron pipes that are mounted overhead throughout the greenhouse and burn gas or oil to generate radiant heat. Reflectors radiate infrared radiation downward, heating the plants but not the air. They have a moderate response time and work best when air movement is minimized. Like any equipment mounted overhead, they create shade.

**Temperature sensors and controls.** Mechanical thermostats have either a bimetal strip or liquid-filled tube that changes length or configuration with temperature and in so doing, operates an electric switch. They are simple, rugged, and require no power. If the heating and cooling equipment are separately controlled, they can act as automatic backups for each other. On the other hand, separate thermostats can work against each other and cannot be connected to computer control systems.

Newer temperature control systems operate from electronic sensors, such as thermocouples or thermistor, that change resistance or voltage in response to temperature. Electronic thermostats have an average temperature differential of less than 1.1 °C (2 °F), compared to mechanical thermostats, which can vary from 2.2 to 5.5 °C (4 to 10 °F) from the true temperature (Greenhouse Manager 1994a). These electronic thermostats require logic devices to read the resistance or voltage and calculate temperature. They may be operated by simple readout devices, dedicated temperature controllers, or environmental control computers and have several advantages. A single sensor can operate all of the heating and cooling equipment and can "stage" temperature control, making it impossible for the heating and cooling to work against each other. Proportional control is possible-instead of a simple ON/OFF response, the system is proportional to the deviation from



**Figure 1.4.2—**Propagation structures can be heated with a large central boiler, which distributes hot water or steam through pipes (A), or with unit heaters, which blow warm air directly into each propagation structure (B).



the setpoint which makes for more precise and efficient temperature control. These systems are readily amenable to computer control and can incorporate many special features, such as separate day and night setpoints, modulating vent or steam valve control, automatic CO<sub>2</sub> injection, and continuous data collection. As a safety measure, many computer systems feature multiple sensors that average readings and provide a cross check in case one sensor fails.

**Heat conservation systems.** A variety of energy conservation devices are available ranging from a simple temperature setback at night to complex systems of electrically deployed thermal insulation blankets. Controls for these devices can be an electric time clock switch or a photocell sensing the coming of night and activating the system. Often, these same systems can control blackout or shade curtains (fig. 1.4.1 A). Computer control systems often incorporate several sophisticated tactics for energy conservation in addition to simply deploying energy conservation hardware.

There are specific strategies for operating efficient heating systems. The first is staging the different components of the heating and cooling system. The second strategy is maximizing the time the greenhouse spends in "neutral," because nothing is being spent to heat or cool it. The only limitation is the tolerance of the crop for the variation in temperature, and that will vary with the species and stage of growth of the seedlings. The third strategy is having a separation in switching temperatures, eliminating short ON/OFF cycles that wear out equipment faster. A temperature differential (**hysteresis**) is built into mechanical thermostats and can be adjusted in many. A common differential is about 0.8 °C (1.5 °F) which means that for cooling, OFF is 1.6 °C (3 °F) lower than ON. A wider differential should be used if the crop can tolerate it. Differentials of any size can be programmed into computer systems, which have more complex control strategies that can maintain extremely accurate temperatures without proportional staging or hysteresis.

The *Greenhouse Climate Control Handbook* (Acme 1988), ASHRAE (1989), and *The Ball Redbook* (Ball 1991) are good sources of additional information on greenhouse cooling and heating.

### 1.4.2.2 Humidity

Humidity control is not feasible in open compounds, shadehouses, or shelterhouses with their sides raised. Humidification equipment is occasionally used in fully controlled greenhouses, especially for vegetative propagation. Dehumidification requires no special equipment but is practical only in enclosed structures.

**Humidification.** Humidification is most commonly needed in arid climates and particularly during the winter when colder air is brought into the propagation structure and warmed. Moisture can be added to the atmosphere in a variety of ways. If it is added as steam, it will already have absorbed the heat of vaporization and will not cool the greenhouse. Steam systems are expensive, however, and are cost effective only when a steam heating system is already in place. Humidity is also increased by short bursts from the irrigation system and from evaporative pad cooling systems.

Fog or mist systems are more commonly used for humidification (fig. 1.4.3A). The difference between fog and mist is one of particle size. Mist droplets are large enough to settle out in a few minutes and cause surfaces to become wet, whereas fog particles remain suspended. Fog systems humidify better but are also much more expensive (table 1.4.1). The choice between fog and mist will depend on the type of crop and cultural objectives. Water may need to be filtered to remove salts or other suspended particles, which can plug the nozzles. Under hot, dry conditions, a typical greenhouse ventilation system produces an air exchange every few minutes, and so fog and mist systems must be capable of delivering short bursts of moisture to humidify the dry replacement air.

**Dehumidification.** Although high humidity is a chronic problem in wet climates, it is generally only necessary to dehumidify the propagation environment after irrigation in most climates. Growers typically open the vents for dehumidification if the ambient conditions are suitable, whereas ventilation plus heating will work regardless of the outside humidity. Underbench heating tubes are particularly effective in dehumidifying the seedling canopy, or some nurseries use portable fans or blowers (fig. 1.4.313). (See volume three, pages 61-64 for more information on humidification and dehumidification.)

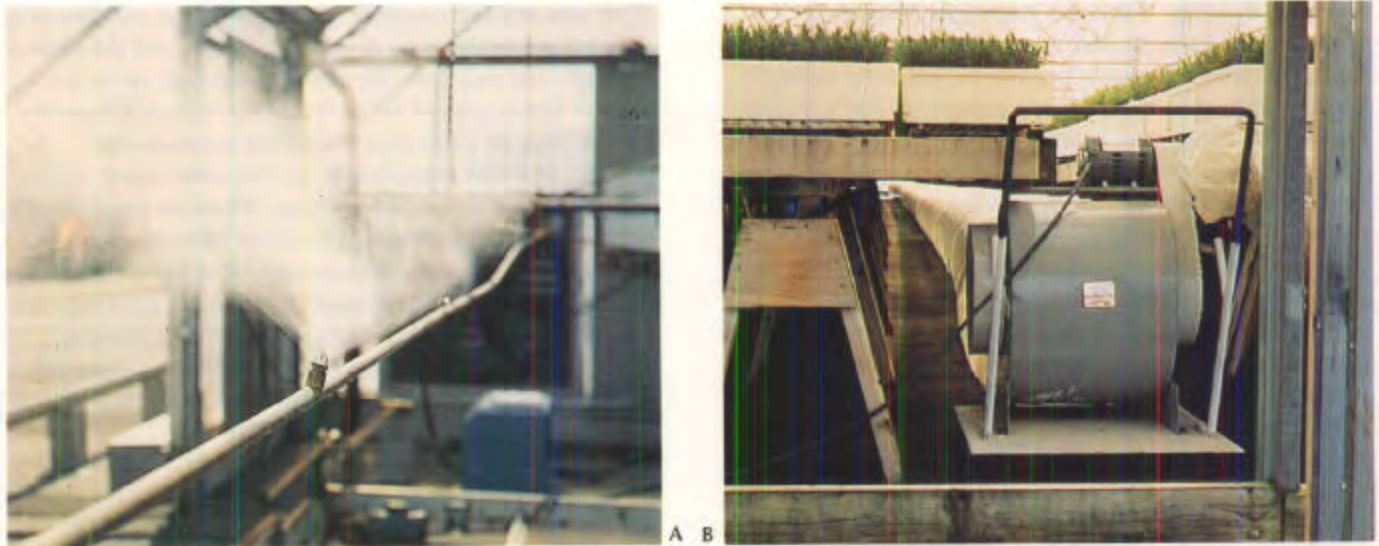

**Figure 1.4.3**—Humidification equipment includes high-pressure mist or fog nozzles (A), while dehumidification can be accomplished by circulating dry air under the benches (B).

**Humidity sensors and controls.** There are a variety of sensors for humidity. **Mechanical humidistats** have hair elements that change length with changes in humidity, triggering ON/OFF switches. They are not very accurate (+ or -10% RH) but are good enough for most greenhouse purposes. Hair elements can get wet without being ruined and are easily and cheaply replaced when they wear out. However, they are also not compatible with modern computer control systems.

**Electrical resistance elements** are impregnated with hygroscopic salts and change resistance with humidity. They are suitable for use with computer controls, but cost more than hair elements and may lose their calibration when exposed to free water. New **bulk polymer sensors** are superior in this regard. **Dew-point sensors** calculate the humidity from the ambient temperature and the temperature at which dew forms on a mirror, which reduces its reflectance. These are very accurate when kept clean and calibrated but are very expensive and more accurate than is needed for container nursery use (More information on monitoring humidity is provided in volume three, pages 66-69.)

### 1.4.2.3 Light

There are three properties of sunlight that can be modified in forest and conservation nurseries: intensity, duration, and quality. In most open growing compounds, sunlight is not controlled, but in propagation structures, the options increase with the sophistication of the nursery design.

**Shading.** The intensity of sunlight can be reduced with shade cloth, lath, and shading compounds that are applied to transparent coverings. Sophisticated retractable shade systems are now available that can sense sunlight intensity to maximize the light reaching the crop during the entire day and under different cloud conditions (fig. 1.4.1 A). Because sunlight is converted to heat when it reaches the crop, artificial shading also is used as the first stage of cooling. Specialized shading systems, called **blackout curtains**, are sometimes used in high-latitude nurseries to exclude sunlight for several hours during the day and induce dormancy in sensitive species. Similar systems are used to extend heat retention curtains during winter nights to reduce heating costs (table 1.4.1).

**Artificial lighting.** There are two types of lighting systems used in forest and conservation nurseries. **Photosynthetic lighting** is used to supplement sunlight intensity during the winter in nurseries at high latitudes. High-intensity lighting systems are expensive to install and operate, however, and so are only considered economical under special circumstances (table 1.4.1).

**Photoperiodic lighting** modifies daylength to prevent seedlings from becoming dormant by reducing the duration of the dark period. This is the most common type of artificial lighting used in container nurseries, and photoperiod lights have been used in all types of propagation environments, from open growing compounds to fully controlled greenhouses.

Photoperiodic lighting involves both **duration** (how long the lights are left on) and **timing** (when the lights are activated). Duration is either continuous or intermittent, and photoperiod lights are turned on after dark or before dawn to extend daylength or at short intervals during the night (fig. 1.4.4A). The best lamp depends on the type of application. Incandescent, fluorescent, and high-intensity discharge lamps differ significantly in light intensity and quality, and each requires its own type of fixtures and controls. Blackout curtains are used in high-latitude nurseries to artificially shorten the daylength during summer and induce dormancy (fig.1.4.4B).

**Light sensors and controls.** The type of control system is determined by the type of lighting system and the choice of lamp. For example, fluorescent and high-pressure sodium lamps cannot be switched on and off frequently but are very efficient when operated for extended periods. Incandescent lamps, on the other hand, are only used for intermittent lighting. Photoperiodic lighting is typically installed in either fixed or mobile systems. Fixed lights are mounted either overhead or at oblique angles around the perimeter of the growing area and are controlled by photocells and timing devices. Some nurseries install photoperiod lights on a movable irrigation boom to produce intermittent lighting patterns. Container nursery developers should contact horticultural lighting experts and talk to other nurseries before designing lighting systems. The book *Lighting for Plant Growth* (Bickford and Dunn 1972) is the best single source of information on horticultural lighting systems. (Shading and artificial lighting systems are also discussed in volume three, pages 83-116.)



**Figure 1.4.4**—Photoperiodic lighting keeps seedlings actively growing by extending daylength (A), and blackout curtains are used in nurseries at high latitudes to shorten daylength and induce budset during the summer (B).

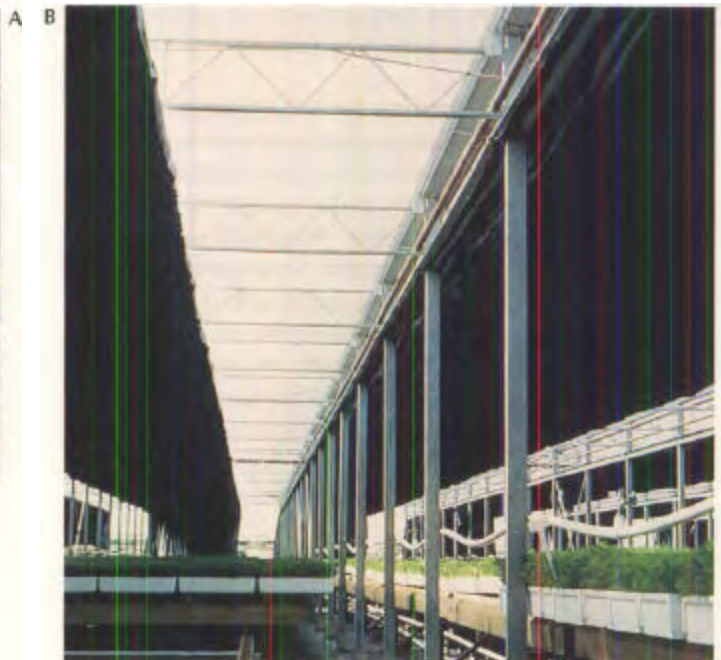

#### 1.4.2.4 Carbon dioxide

Carbon dioxide enrichment is not widely practiced in forest and conservation nurseries but is relatively economical in fully controlled propagation structures (table 1.4.1). The practicality depends on the type and condition of the structure because it is difficult to maintain proper carbon dioxide levels in leaky houses.

**Increasing carbon dioxide.** There are two options for supplying carbon dioxide (CO<sub>2</sub>) to propagation structures: pressurized gas and combustion of fossil fuels (fig. 1.4.5). Pure CO<sub>2</sub> can be injected from a pressurized tank through perforated pipes (the safest technique), or CO<sub>2</sub>

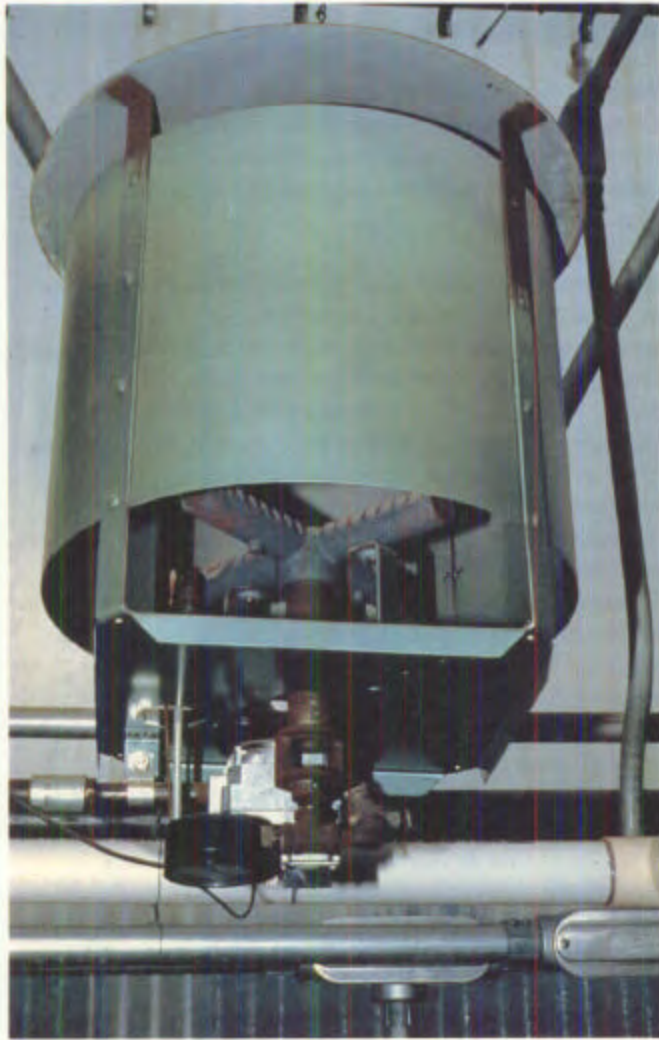

**Figure 1.4.5**—Burning propane increases carbon dioxide levels within enclosed growing structures.

can be generated by combustion of propane or natural gas in burners located throughout the house. Carbon dioxide can be added anytime during daylight hours whenever the vents are closed. The strategy is to begin raising the CO<sub>2</sub> level several hours before dawn and then shutting the generators down when ventilation begins.

**Carbon dioxide sensors and controls.** Carbon dioxide enrichment is controlled by solenoid valves that regulate the burner or the tank, and is synchronized with the vents or fans. The rate of CO<sub>2</sub> addition can be set using rules of thumb regarding the size and leakiness of the greenhouse, but it is better to measure the rate. There is some relatively inexpensive testing equipment on the market that is adequate for determining the rate of CO<sub>2</sub> enrichment. Once the equipment has been calibrated, periodic spot checks are useful but continuous monitoring is not necessary. For sophisticated environmental control systems, infrared gas analyzers can monitor and control CO<sub>2</sub> levels very precisely. The book *CO<sub>2</sub> Enrichment in the Greenhouse: Principles and Practices* (Hickleton 1988) is the best reference on horticultural control of carbon dioxide. (Also, see volume three, pages 132-138, for more detailed information.)

#### 4.2.5 Irrigation

An efficient and reliable irrigation system is required for all container nurseries and, in contrast to other types of environmental control equipment, the basic systems are similar from open compounds to fully controlled greenhouses.

**Irrigation systems.** Sprinkler irrigation is the norm in forest and conservation nurseries. Drip irrigation is not practical with small containers, and other irrigation techniques, such as capillary mats, do not permit air pruning of the root system. A typical sprinkler irrigation system consists of a pump, pressure tank, pipes, and sprinkler heads. Nurseries in developed areas sometimes can use water from municipal water systems and pipe it directly through a pressure regulator to the sprinklers. If a well is necessary, the water is pumped to a pressure tank that acts as temporary storage and a pressure buffer. Although galvanized piping was used in older nurseries, plastic polyvinyl chloride (PVC) pipe is now the most common because of its low cost and desirable physical properties. The building codes in some States stipulate which types of pipes must be used so local officials must be contacted (Bartok 1991).

Within the propagation area, two irrigation systems are common: fixed sprinklers or a mobile boom (fig. 1.4.6A&B). Fixed sprinklers are laid out on a grid and are the most economical option (table 1.4.1). Mobile irrigation booms are more expensive but apply water more evenly and only to the propagation areas, thus reducing runoff. A wide variety of different boom irrigation systems are now available. New computer-equipped booms offer precise control of irrigation, allowing sections to be skipped or irrigated repeatedly to meet the requirements of specific crops (Greenhouse Manager 1993A). Details on designing an irrigation system are presented in Aldrich and Bartok (1989), Pair and others (1983), and Melby (1988).

**Monitoring and regulating irrigation.** The irrigation methods used in container nurseries vary considerably, based on crop requirements and the type of irrigation system. Small propagation areas may be watered by hand with a hose, and this is still the best technique for some sensitive species. The next step in complexity is a fixed array of sprinklers that are manually operated. This increases the size of the propagation area that can be controlled, but someone has to be there to turn it on and off. Manual operation has some definite quality control advantages because the irrigator is always around to make sure that the system is operating properly and that the seedlings are receiving the proper amount of water. This can be inconvenient on weekends and holidays, however, and so most nurseries use some sort of automated irrigation system.

The simplest form of irrigation controller is a **time clock** to control a series of solenoid valves that turn the water on and off in each irrigation zone of the propagation area. These controllers can be programmed to time the duration of irrigation in each zone, thus allowing the irrigator to adjust the amount of water applied to the demands of each crop. This makes irrigation at night and on weekends possible but has the disadvantage that the same amount of water is applied every time regardless of climate or crop condition. Therefore, growers using time controllers try to arrive at some estimated plant water use. For example, some nurseries monitor evapotranspirational losses by weighing a typical block of containers. Because water is a major part of block weight, growers can monitor water use by weighing the blocks and determining when to irrigate (fig. 1.4.60).

Environmental computers use "on-demand" control systems to regulate irrigation by monitoring accumulated light, vapor pressure deficit, or evaporative demand. Research with tensiometers, which measure the matric potential of the growing medium, has also shown promise (Whitesides 1993). Although these new computer systems offer new possibilities, personal monitoring of irrigation is still the norm in forest and conservation nurseries. Irrigation is such a critical part of nursery culture and seedling water use can change so rapidly in propagation environments that reliance on a fully automated control system is not recommended without regular supervision. (See volume four, pages 95-109, for more information on irrigation systems and monitoring techniques.)

### 1.4.2.6 Fertilization

Because the artificial growing media used in most container nurseries are essentially infertile, the 13 mineral nutrients that are required for normal plant growth and development are supplied through fertilization.

**Fertilization systems.** The primary fertilization methods in forest and conservation nurseries are (1) adding soluble fertilizers to the irrigation water (**fertigation**), and (2) incorporating solid fertilizer into the growing medium. Most container nurseries inject soluble fertilizer through the irrigation system because it is the easier and more accurate way to apply and monitor mineral nutrition. There are two ways of doing this. The fertilizer can be added to a large tank of water, dissolved, and then pumped onto the crop. Alternatively, the fertilizer can be made up as a concentrated solution that is then injected into the water line during irrigation (fig. 1.4.7A). The latter is the most common method because, at concentration ratios of 1 :100 or 1:200, the tanks and injectors take up much less room than a tank large enough to hold the diluted fertilizer solution. Many different fertilizer injectors are available, from simple hose siphons to mechanical pumps using water pressure or electricity; compared to other nursery equipment, injectors are relatively inexpensive (table 1.4.1). Fertilizer injectors are normally located with the irrigation controls in the headhouse. It is a good idea to install backflow preventers on the water lines to be sure that potable water does not get contaminated with fertilizer; in fact, they are legally required in many areas.



A



B

**Figure 1.4.6**—Fixed irrigation systems use sprinkler nozzles that throw a circular pattern (A); movable boom systems distribute an even curtain of water over sections of the growing area (B). Weighing sample containers is a fast and easy way to monitor water use by seedlings (C).



C



A



B



C

**Figure 1.4.7**—Injection of fertilizer solutions into the irrigation system (fertigation) is an efficient way to supply mineral nutrients (A). Granular fertilizers, like these Osmocote® pellets, can be incorporated into the growing medium (B). Computerized fertigation systems are now being used to precisely control mineral nutrient injection (C). (C, courtesy of E. Labbate, Climate Control Systems, Leamington, ON.)

The second fertilization technique is incorporation of slow-release fertilizers into the growing medium when it is being mixed (fig. 1.4.7B). This method is less popular because it is difficult to obtain even mixing of the fertilizer pellets in the small volume of growing media in the small containers typically used in forest and conservation nurseries. The other drawback is that, once the slow-release fertilizers are incorporated, there is no way to control the nutrient release rate. Some container nurseries use a combination of slow-release fertilizers and fertigation.

**Monitoring and regulating fertilization.** Liquid fertilizer injection is controlled with the same equipment as the irrigation system. Automated controls that monitor inline salinity and are linked to the overall environmental computer system are now available. Salinity measurements only give a rough idea of total fertilizer levels, however, not the concentration of individual mineral nutrients. Although sensors for specific nutrient ions are available, they are not practical for operational nurseries. Specialized fertigation controls (fig. 1.4.70) use computer programs to regulate the concentrations of individual nutrients as a proportional response of total salinity, and can maintain accuracies to within 10% (Labbate 1994). Many growers monitor fertility by testing the concentration of nutrients in the applied irrigation water or the leachate that drains from the container. There is no automated way to monitor the amount of dry fertilizer that is incorporated into growing media. (See volume four, pages 26-58, for more information on fertilization methods and monitoring.)

#### 1.4.2.7 Environmental control systems

**Discrete and dedicated controls.** These single-function controllers (e.g. thermostats) regulate one piece of equipment with a simple ON/OFF switch. Currently, around 90% of existing greenhouses still rely on mechanical thermostats (Greenhouse Manager 1994a). One common thermostat contains a bimetallic strip that is sensitive to changes in temperature and activates a switch when it senses a change. Thermostats are used to regulate temperature control equipment such as heaters, fans, and vents (table 1.4.2). Other types of discrete and dedicated controls do not sense the propagation environment at all but use time clocks to regulate irrigation solenoids, photoperiod lights, or carbon dioxide generators. They can operate independently or be linked in sequence. This redundancy of function means that if one device fails, the rest of the system keeps working. Discrete and dedicated controls are inexpensive but

must be calibrated routinely. Thermostats are particularly unreliable, and response varies from instrument to instrument and can change over time (Nelson 1991).

**Analog and integrated controllers.** A wide variety of controllers are available that can regulate many different environmental variables (table 1.4.2). They use proportioning thermostats and other electric sensors to gather information from the propagation environment, and then rely on electronic logic circuitry to process this information, make decisions, and operate a single piece of environmental control equipment. Analog controllers are limited to a single sensor and can control only one propagation environment (Ball 1991). Many are "hardwired systems," which means that they are not directly programmable, whereas others have limited programmability. Analog controllers can also be wired to activate alarm systems, such as when the temperature decreases past a set point.

Environmental controllers are commonly linked to provide multiple functions and operate in **stages** to maintain the desired temperature by switching an increasing sequence of heating or cooling (fig. 1.4.8). For example, consider a situation in a greenhouse early in the morning. Neither the heating nor cooling is operating; the house is in "neutral." As the greenhouse heats up, the temperature reaches the first cooling setpoint and one of several fans comes on. If that gives sufficient cooling, nothing further happens, but if the temperature continues to rise and reaches the second cooling setpoint, a second fan comes on. If all of the fans are on, and cooling is still not adequate, then the pump comes on and begins circulating water through the wetwall and evaporative cooling—the third stage of cooling. As the greenhouse cools down, the sequence reverses. Heating stages consist of a sequence of burners and heat distribution fans.

**Climate control computers.** The computer revolution has radically changed the way in which the environment in propagation structures is controlled. Climate control computers use microprocessors to combine information from a variety of sensors and provide an integrated view of all factors in the propagation environment (fig. 1.4.9). Computers can sense and record climatic information from an outside weather station as well as atmospheric or growing medium conditions within the propagation structure. Climatic indexes, such as vapor pressure deficit, used to be difficult to monitor in operational nurseries but this task is now possible with computers.



**Table 1.4.2—Features of environmental controls for propagation structures**

	Type of environmental controls		
	Discrete/ dedicated	Analog/ integrated	Computer system
<b>Functions</b>			
Multiple sensors	No	No	Yes
Multiple structures	No	No	Yes
Proportional switching	No	Yes	Yes
<b>Seasonal adjustments</b>			
Clock time	Maybe	Maybe	Yes
Solar time	No	Maybe	Yes
Weather stations	No	Maybe	Yes
Record and store data	No	No	Yes
Programmable	No	Limited	Yes
Price range	\$50–250	\$800–1,600	\$3,000–50,000+
<b>Environmental factors*</b>			
<b>Temperature</b>	Heaters Vents Fans	Heaters Vents Fans Wet wall Heat curtain	Heaters Vents Fans Wet wall Heat curtain
<b>Humidity</b>	Humidistat	Heat Vents Mist nozzles	Heat Vents Mist nozzles
<b>Light</b>	Time clock	Lights Shade curtain Blackout curtain	Lights Shade curtain Blackout curtain
<b>Carbon dioxide</b>	Time clock	Yes	Yes
<b>Water</b>	Time clock	Irrigation Mist nozzles	Irrigation Mist nozzles
<b>Mineral nutrients</b>	Ratiometric Injector	pH Salinity	pH Salinity Nutrients

\* Note that each environmental factor requires a separate piece of discrete/dedicated equipment or a separate type of analog control and these must be integrated.

Source: Ball (1991), Mackenzie (1993).



**Figure 1.4.8**—Climate controllers regulate heating and cooling in a series of stages around the desired set point temperature.

Computers are essential in high-tech greenhouses to integrate all the various environmental control equipment. Instead of only switching a single piece of equipment ON or OFF, climate control computers can modulate, which produces an infinite number of adjustments. They also compile and analyze the full complement of environmental data to make "intelligent" decisions (Argus Control Systems 1990). For example, during the winter, light sensors tell the climate computer that the sun is setting, and so the demand for heat can be anticipated before the temperature actually begins to drop (Ball 1991). Increasing energy costs and concern about excess fertilizer runoff make computer control

systems even more attractive. Documented energy savings can range from 15 to 30% for typical nurseries to as high as 40 to 60% for high-tech greenhouses with all the latest equipment (Whitesides 1991).

A typical system consists of a central computer terminal and individual controllers and alarms at different locations throughout the various propagation environments (fig. 1.4.9). One terminal should be located in the headhouse so that personnel can instantaneously monitor all environmental factors in each propagation environment, as well as analyze stored data to compute trends and detect problems. Many growers also install computer terminals in their homes so that they can respond to potential problems without having to go to the nursery. One of the greatest advantages of climate control computers is that they are able to accurately record what really happens in the nursery so that this information can be used for troubleshooting and fine-tuning environmental control equipment (Bartok 1993). Computers also can be linked to a more sophisticated alarm system that can be redundantly programmed. With this technology, computers can often identify the location and nature of a problem, so that the grower is not needlessly bothered.

Nurseries with propagation structures larger than 2,000 m<sup>2</sup> (21,500 ft<sup>2</sup>) can usually justify computer control systems, which pay for themselves in 3 to 5 years (Mackenzie 1993). Computer systems come in many different models, offering a wide variety of different features (Greenhouse Manager 1994b). Developers should consult with other nurseries and suppliers to make sure that the system is well matched to their requirements. Maintenance is rarely a problem because replacement parts can usually be obtained by overnight courier, and companies offer specialist support by telephone.

#### 1.4.2.8 Nursery security and emergency equipment

Forest and conservation seedlings are a valuable crop and so it makes good sense to protect this investment with a security system. Seedlings grown in greenhouses are particularly succulent and can be damaged or killed by only a few hours of excessively high or low temperatures. Less sophisticated security systems are needed for simpler growing structures or open compounds, which may only require a low-temperature alarm for unseasonal frosts.

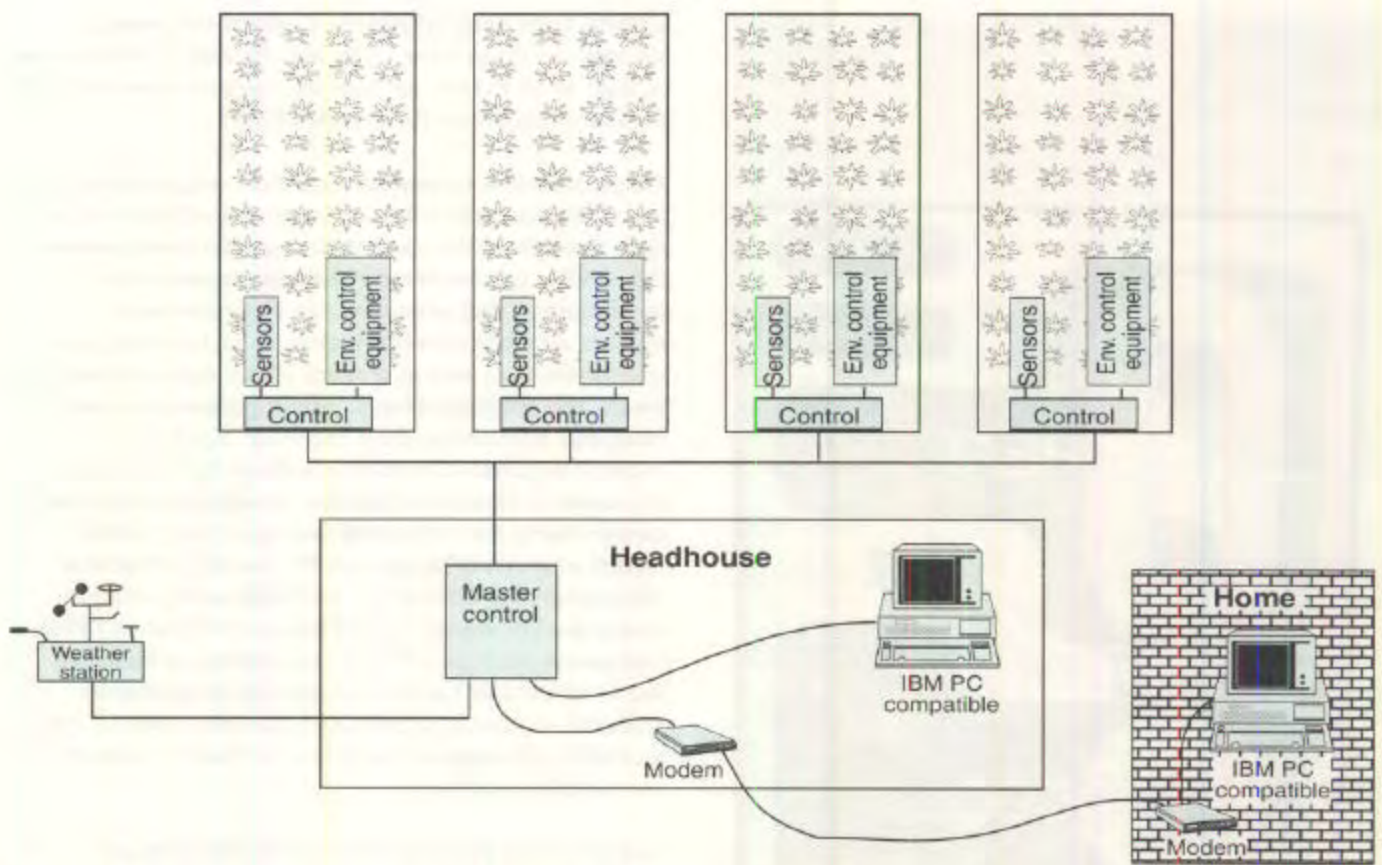

**Figure 1.4.9**—Climate control computers precisely regulate environmental control equipment by monitoring weather conditions both inside and outside the propagation structures, and feature remote access and permanent data recording (modified from Argus 1990, Hummert 1993).

A variety of different security systems are available and can alert the nursery manager in case of electrical power failure, mechanical problems with environmental control equipment, fire, or burglary. Alarm systems are relatively inexpensive, ranging from around \$50 for a simple bell temperature alarm to automatic telephone dialing units that can be purchased and operated for a couple of hundred dollars per year. The cost varies with the type of sensor and alarm system. Many types of sensors are available that can detect almost any type of emergency situation, from simple thermostats or thermistors that detect temperatures that are too high or too low to ultrasonic sensors that can signal an unwanted intruder (Bartok 1987). Alarm systems range from bells and sirens to sophisticated alarms that can automatically dial a sequence of phone numbers in case the first is busy or does not answer. Computer alarm systems can detect

and indicate specific equipment failures. These "smart systems" allow the grower to diagnose many problems from home so that traveling to the nursery may not be necessary.

Standby electrical generators are essential for most nurseries because power failure is an unfortunate reality, especially in remote areas where many container tree nurseries are located. Loss of electrical power can be disastrous during cold periods because most growing structures rely on electricity for fuel ignition and heat distribution. Conversely, in hot climates, electricity is needed to run ventilating fans and cooling system water pumps. Used generators are available from surplus equipment stores and should be sized to operate all critical equipment. A minimum of 1 kilowatt (kW) of generator capacity is generally adequate for every



A



B

184 m<sup>2</sup> (2,000 ft<sup>2</sup>) of growing area (Nelson 1991). Small to medium-sized generators can utilize existing natural gas or propane but larger machines are best suited to diesel fuel. Because gasoline can become stale, it should only be considered for small portable generators that are used on a regular basis. With proper ventilation, generators can be located inside structures, or outside on a concrete pad (fig. 1.4.10A). To limit noise, a residential-grade exhaust system should be specified. Fully automatic control systems are available that constantly monitor line voltage, start and stop, and recharge their batteries without an operator. All generators must be serviced routinely and should be run through a full load test at least once a year (Charlton 1992).

Propagation structures that rely on fossil fuels for heat rarely have alternative heating systems to ensure that heat is available in case of loss of the primary fuel supply. Problems with natural gas supplies are rare, but supplies of fuel oil or propane should be monitored and refilled regularly to maintain an adequate reserve. Portable radiant heaters can be used as an inexpensive backup heat source as long as proper ventilation can be provided (fig. 1.4.1 OB). Salamander heaters burn kerosene at a rate of 1.9 to 3.8 liters/h (0.5 to 1.0 gal/h) and can protect up to 140 m<sup>2</sup> (1,500 ft<sup>2</sup>) of production area in a propagation structure (Nelson 1991).

Crops grown with photoperiod lights or blackout curtains are extremely sensitive to equipment failure. For example, if photoperiod lights fail for only one night, shoot growth can cease and the seedlings will set a dormant terminal bud—a situation that is difficult or sometimes impossible to reverse within the growing season. The most direct way to monitor the lighting system is to link a photocell to the lighting controls, which is a standard feature of most computer alarm systems.

**Figure 1.4.10**—An electric backup generator big enough to run the essential environmental control equipment is a good investment (A). Portable heaters can provide protection in an emergency but the structures must be properly ventilated (B).

### 1.4.3 Benches and Supports for Containers

The process of growing seedlings consists of a sequence of operations that begins when the seeds or cuttings are delivered to the nursery and ends when the seedlings are shipped to the outplanting site (fig. 1.4.11). Before this can happen, however, the propagation area must be outfitted with some sort of support system for the containers.

Container crops can be grown directly on the floor, on pallets, racks, or raised benches, and the choice is critical from both a biological and operational standpoint. The way in which forest and conservation plants are positioned affects their growth and development. Whereas other crops may be grown directly on the floor or on traditional benches, container tree seedlings have

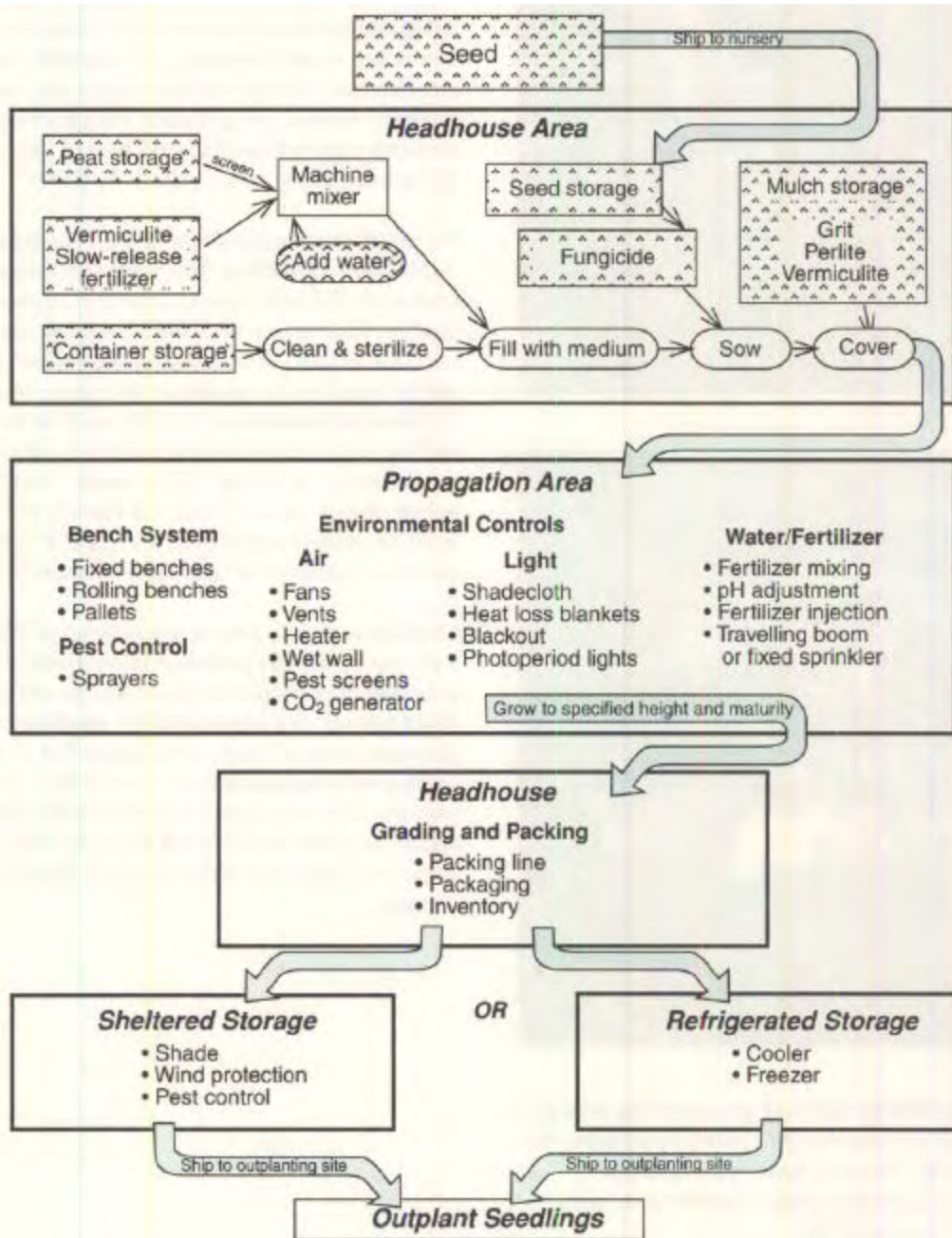

**Figure 1.4.11**—Production of a container tree nursery crop consists of a series of sequential processes and operations (modified from Conway 1987).

aggressive root systems that quickly grow out the bottom of the container (fig. 1.4.12A). The roots from seedlings in containers on the ground will grow into the soil (fig. 1.4.12B). These external roots must be pruned before the seedlings can be shipped, which not only requires extra labor but also reduces seedling quality. To cause roots to desiccate and **air prune**, an air space must be

provided under the container. Some containers are designed so that they promote air pruning (fig. 1.4.12C), but others must be grown on benches with wire mesh or other supports to create the necessary air layer (fig. 1.4.12D).

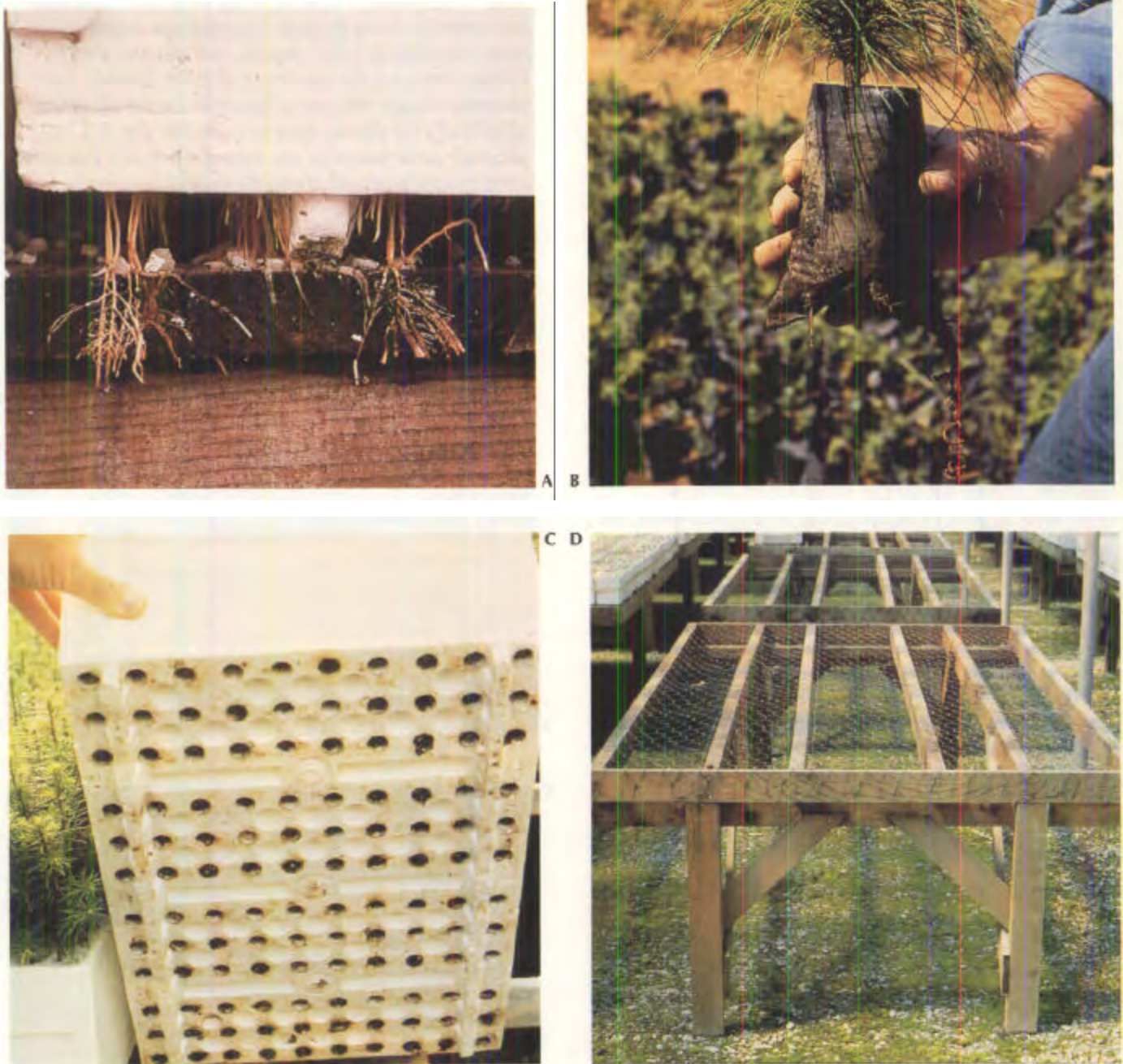

**Figure 1.4.12**—Tree seedlings have aggressive root systems (A & B) that need to be “air-pruned” by providing an air space under the containers. Some types of containers have special supports (C), but they should still be placed on benches designed to promote air pruning (D).

Operationally, containers must be positioned so that they make the most efficient use of the propagation area and can be easily handled and moved. The container support system must be compatible with the handling system; a nursery that is designed to move seedlings with forklifts will have a different system than one using conveyors. Aisles provide access for workers and equipment, but they also reduce production space. Main aisles of 0.9 to 1.5 m (3 to 5 ft) and side aisles of 0.5 to 0.8 m (1.7 to 2.5 ft) are typical (Aldrich and Bartok 1989).

### 1.4.3.1 Pallets

Container nurseries that are designed to maximize materials handling use some sort of wood, synthetic, or metal pallets that can be handled by pallet jacks or forklifts (fig. 1.4.13A). The dimensions of the pallets must be designed so that they can be easily moved by the handling equipment and also must fit through the door of the propagation structure (fig. 1.4.13B). Access must also be considered for buildings such as the headhouse, if that is where the containers will be sown or the seedlings packed. Pallets should be constructed so that they will stack easily to save space when not in use (fig. 1.4.13C). Calculations for designing pallets so that they accommodate the maximum number of containers as well as fit within the propagation structure are given in section 1.3.4.3 of this volume.

### 1.4.3.2 Benches

Benches put seedlings at a safe and comfortable working height for thinning, weeding, and other cultural tasks, including inspections for diseases and other problems. In propagation structures with heating and cooling systems, benches allow good air circulation under the crop. Under-bench heating is not only more efficient, but warm air rising through the seedlings warms their roots, stimulating better growth, and also dries their foliage, reducing the incidence of foliar disease. For maximum space efficiency, benches can be designed specifically for a given type of container (fig. 1.4.14A) although most nurseries use a standard bench that will accommodate several container types.

**Stationary benches.** The surface dimensions vary considerably, but bench height is fairly standard at about 70 to 80 cm (28 to 32 inches), which is best for safe and comfortable working. Widths from 1.2 to 1.5 m (4 to

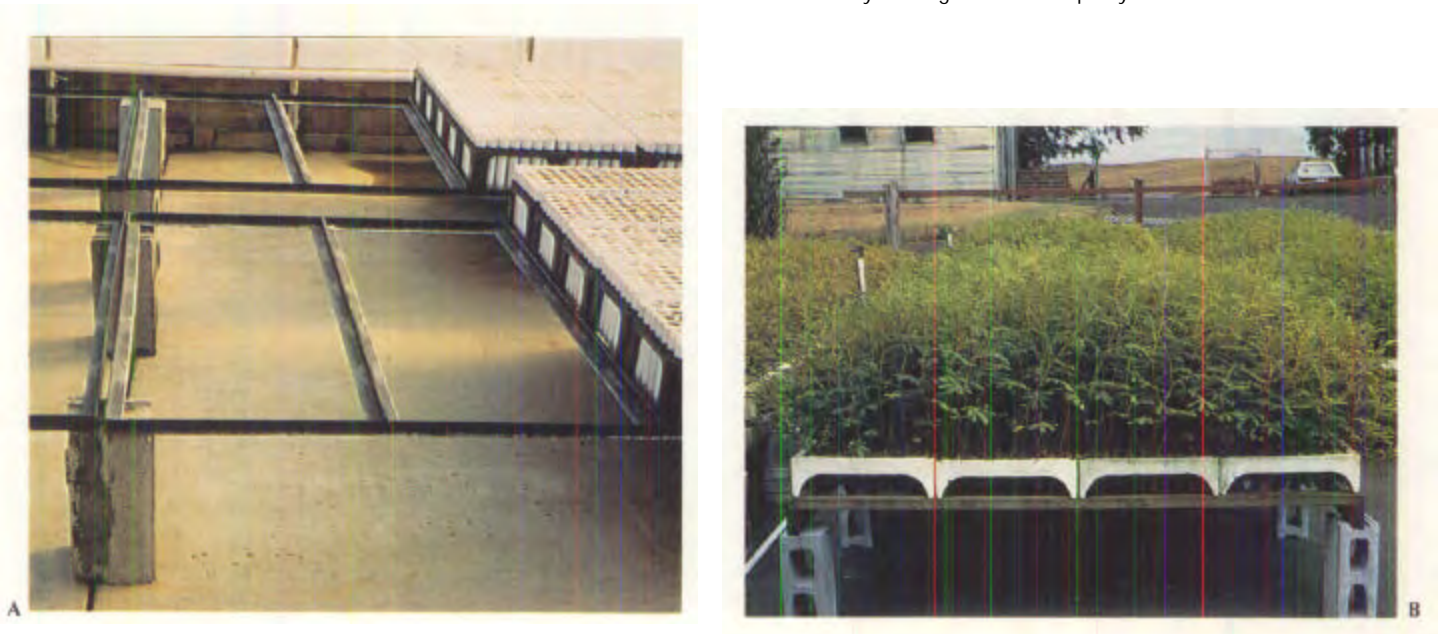

**Figure 1.4.13**—Containers grown on pallets are moved by pallet jacks or forklifts (A) into the propagation area (B). Although some nurseries use standard wooden pallets, others construct specially designed metal ones that promote air pruning and stack when not in use (C).

5 ft) allow workers to reach containers in the middle (Aldrich and Bartok 1989). Many stationary benches are homemade, consisting of wooden or concrete block legs and wooden or metal frames (fig. 1.4.14A&B). If they are not designed for one particular type of container, bench tops are constructed of heavy-gauge wire screening (fig. 1.4.12D) or galvanized expanded metal (fig. 1.4.14C) so that any type of container can be used. The

cost of stationary benches can vary considerably based on type of materials and design features (table 1.4.3).

**Movable benches.** Movable or rolling benches are a rather recent innovation that, while allowing good access, increase the production space efficiency as much as 10 to 25%. They are constructed of metal or wood and are of two general designs (fig. 1.4.15). The lateral design features permanent bench supports, but the bench tops move laterally so that an aisle can be created at intervals by moving the bench tops by hand



**Figure 1.4.14**—Many stationary benches are designed to accommodate a specific container (A), while others hold many different types. Benches can be “homemade” of readily available materials (B) or specially constructed of aluminum or galvanized metal to resist decay and corrosion (C).

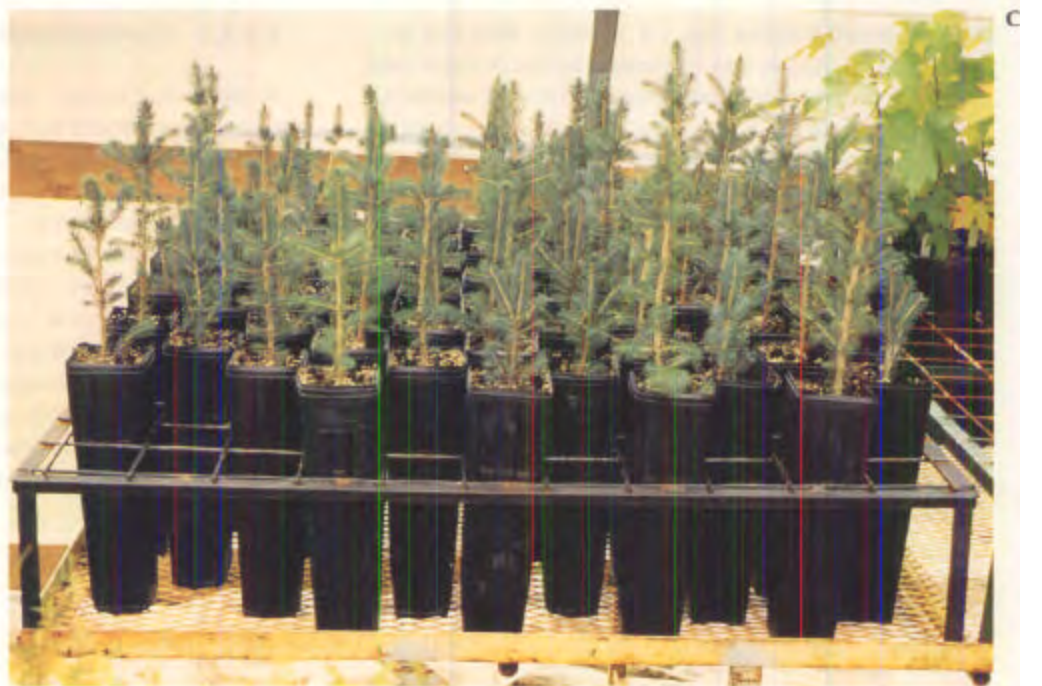



**Table 1.4.3—Planning cost estimates for typical seedling production equipment**

Type of equipment	Cost	Production information	Source
<b>Benches</b>			
Stationary	\$16.14–48.42	Per m <sup>2</sup> of area	Aldrich and Bartok (1989)
	\$ 1.50– 4.50	Per ft <sup>2</sup> of area	
Movable	\$34.43–51.65	Per m <sup>2</sup> of area	Aldrich and Bartok (1989)
	\$ 3.20– 4.80	Per ft <sup>2</sup> of area	
<b>Container handling</b>			
Belt conveyor	\$ 8,000	75 ft + drive section	Chris (1993)
<b>Loading containers</b>			
Block washer	\$ 5,500	7 – 10 trays /min	McConkey (1993)
Growing media mixer	\$ 10,000	1.5 m <sup>3</sup> /3 min	McConkey (1993)
		2 yd <sup>3</sup> /3 min	
Flat filler	\$ 13,000	6 – 30 trays/min	McConkey (1993)
<b>Seeders</b>			
Shutterbox	\$ 100	Up to 250 trays/h	N/A
Vacuum plate	\$ 500	Up to 500 trays/h	Speedling (1993)
Vacuum drum	\$ 8,000	50–500 trays /h	Elston (1991)
Precision	\$ 10,500	20–200 trays/h	Elston (1991)
Automated sowing line	\$100,000	500–1,000 trays/h	Reid (1994)
Grading/packing line	\$ 3,000	Worker dependent	McConkey (1993)

or with special handles (fig. 1.4.15B&C). Benches as long as 61 m (200 ft) can be moved in this manner and, when the access aisle is not needed, then the sections can be rolled together to produce a continuous bench. Aisles are typically about 46 cm (18 in) wide although they can be expanded to 69 cm (27 in) if more space is required (Aldrich and Bartok 1989). The end-to-end movable benches feature a permanent middle aisle and pallets that move end-to-end on benches with rollers. With this design, a side aisle can be created where needed and the pallets can even be moved out of the propagation structure through the endwall (fig. 1.4.15D&E). Movable benches can be fabricated at the nursery or purchased commercially (Greenhouse Manager 1993); their higher cost must be balanced against the increased production space (table 1.4.3).

### 1.4.3.3 Construction materials

In the humid nursery environment, the frames of pallets or benches should be constructed of aluminum or galvanized steel to resist rusting, or pressure-treated wood must be used to prevent decay (see section 1.3.3.4 for further discussion). The bench supports can be made of several different materials, including treated wood, metal pipe, or concrete blocks. Raised benches should be able to support at least 122 kg/m<sup>2</sup> (25 pounds per square foot). Bench tops are made of wire mesh, expanded metal, or wooden slats to promote good drainage and air pruning. Wire mesh tends to sag if not properly supported, whereas expanded galvanized metal, although more expensive, is much sturdier (Langhans 1980).

**Figure 1.4.15**—In recent years, movable or rolling benches have become more popular and are of two general types (A). With the lateral design, the bench tops are moved sideways by hand or with special crank handles (B & C) to generate a temporary aisle. The end-to-end design features pallets that roll lengthwise in the propagation structure (D) and can even be used to transport the containers for hardening or shipping (E). (A, adapted from Aldrich and Bartok 1989.)

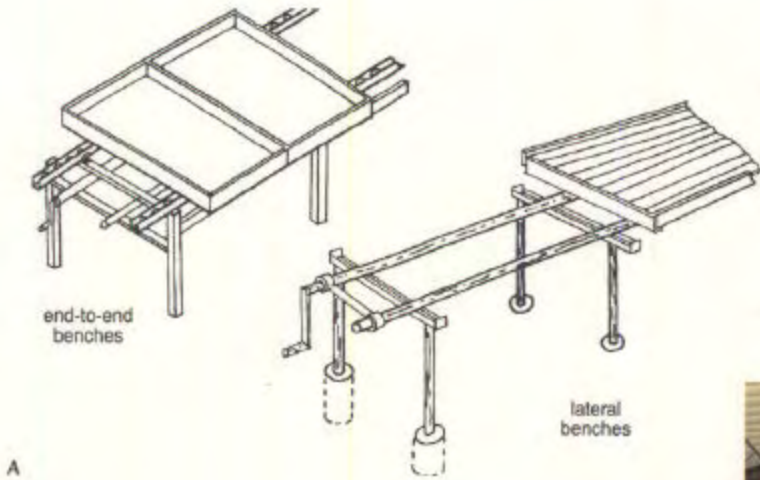

A



C

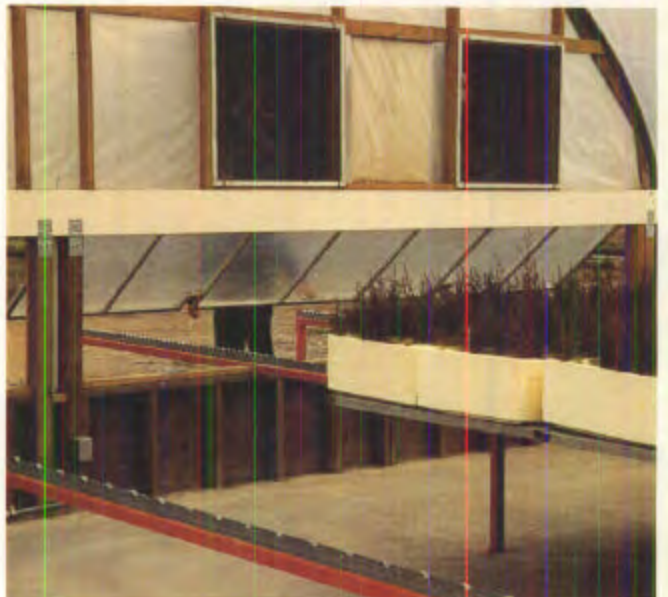
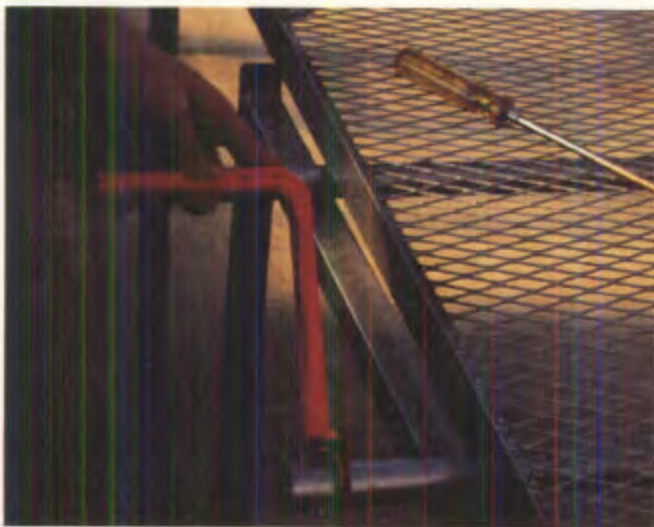

Molded plastic pallets and benches are just recently being marketed, and some are constructed of recycled plastic or plastic/wood composites. The surface of these new materials will not splinter and is smooth so that containers will slide easily. Plastics also clean easily, which is a real consideration for preventing development of algae and moss and sanitizing between crops. Lumber made of recycled plastic/wood composites is 20 to 30% heavier than natural wood, and some types flex slightly under warm temperatures. Costs are competitive with those of pressure-treated lumber (Sorvig 1993).

#### 1.4.4 Handling Equipment for Materials and Seedlings

After the container support system has been selected, then the best way to move seedlings and materials throughout the nursery must be decided. Every nursery must have a system for moving materials from storage areas to work areas, and containers in and out of the growing area (fig. 1.4.11). Some nurseries use the same method of transport throughout all processes, such as those designed around a pallet system, and some can be quite sophisticated (fig. 1.4.16A&B). Other nurseries use a combination of equipment.

The handling system must be decided early in the nursery development process because it helps determine both structure design and location. In designing a handling system, emphasis should be placed on minimizing wasted time and motion, and flow diagrams should be sketched for all key operations such as container sowing and packing. The novice developer should visit other container nurseries during these

operations to get an idea of the processes involved. The handling system should be designed so that key equipment and workers are supplied with a constant flow of materials. For example, the critical operation in a hand sowing line is done by the person doing the seeding, and so keeping this person supplied with filled containers will reduce labor expenses and make the entire operation go more smoothly. Many nurseries use conveyors to move sown containers into the propagation area and mature seedlings to the packing shed. Bartok (1986) provides a good discussion of other considerations for designing an efficient, but safe, system for handling materials.

Typical handling systems use conveyors, carts, and pallets to move seedlings and materials through the nursery. Their costs will vary with the sophistication of the system.



**Figure 1.4.16**—Container handling systems move seedlings from the propagation area, to the hardening area (A) and then to the outplanting sites (B) and some are quite sophisticated.

### 1.4.4.1 Conveyors

Conveyors are often used to speed container movement during sowing or packing and to move filled containers to the propagation areas. There are 4 common types: roller conveyors, belt conveyors, chain conveyors, and trolley conveyors. Roller conveyors are unpowered and are available in 1.5- to 3.0-m (5- to 10-ft) sections on which the materials are physically pushed by hand (fig. 1.4.17A). They are somewhat limited because materials must have smooth, flat bottoms or be placed on a piece of plywood. Belt conveyors (fig. 1.4.17B) are powered by electric or hydraulic motors and are available in a variety of widths and lengths; heavy-duty models can handle 136 to 182 kg (300 to 400 lbs). Folding and extension belt conveyors come in sections and can reach as far as 30 m (100 ft). Chain conveyors are similar but use moving chains instead of belts; they also require containers with smooth bottoms (fig. 1.4.17C). The last category is trolley conveyors, which are not powered and run on an overhead track connected to the frame of the growing structure (fig. 1.4.17D). This use must be considered during construction so that the structures can handle the added load (Bartok 1991 b).



**Figure 1.4.17**—Several types of conveyors are available for use throughout the nursery system. Roller conveyors (A) are unpowered but belt conveyors (B) and chain conveyors (C) use electrical motors to transport containers or materials.





D

Conveyors are particularly useful during sowing and packing to move the containers along the line and also to supply materials to the workers (fig. 1.4.17E). With large automated container filling and sowing equipment, belt elevator conveyors are used to keep hoppers supplied with growing media. With the variety of different conveyors that are available, nursery developers must carefully consider the full range of uses before making a selection.

**Figure 1.4.17 (continued)**—Several types of conveyors are available for use throughout the nursery system. Trolley conveyors (D) are attached to the propagation structure or irrigation boom. Conveyors are an essential component of container filling, sowing, and packing lines (E).



E

### 1.4.4.2 Hand carts and motor vehicles

A wide variety of wheeled carts, trailers, and motor equipment has been used to move seedlings and materials in container nurseries. Smaller nurseries rely on hand carts and pallet jacks for materials handling (fig. 1.4.18A). Forklifts and tractors with forklift attachments have many uses in container nurseries but can only be used on solid floors (asphalt or concrete) that can support such equipment (fig. 1.4.18B). Small motor carts with trailers are commonly used, but operating internal combustion engines in closed spaces where people are working is dangerous. So, electrically powered or propane-powered equipment is recommended (fig. 1.4.18C). Nurseries growing their seedlings in open compounds can use fuel-powered tractors and trailers, some of which have been custom-made to handle containers (fig. 1.4.18D).



B



C



D



**Figure 1.4.18**—Containers and supplies are handled by pallet jacks (A), fork lifts (B), or carts (C), which must be powered by propane or electricity in closed areas for safety reasons. Fuel-powered tractors and trailers can be specially modified to transport seedlings in open growing areas (D).

## 1.4.5 Seedling Production Equipment and Supplies

The objective of this section is to give the nursery developer an idea of what will be needed to produce that first crop. The container tree nursery **system** can be broken down into separate **processes** (e.g., sowing seed) that consist of **operations** (e.g., placing the desired number of seeds per container). Each of these processes have specific **requirements** including equipment (e.g., seeding machine) and supplies (e.g., seed and electricity). (See section 1.1.4 for more discussion on this concept and terminology.)

To be most efficient and cost effective, seedling production equipment should be chosen so that it fits into an overall sequence (fig. 1.4.11). All the various steps in the process can be done by hand and so the need for equipment is dependent on the size and complexity of the nursery and the resources available. Worker safety is also a consideration because many operations can lead to fatigue and injury, especially tasks requiring repetitive motion, and so should be mechanized if possible. The propagation method for a particular species is also a consideration. With some crops, equipment cannot be justified, but for others, it would be strongly advised. For example, a nursery growing 2 million pine seedlings could significantly cut production costs by purchasing a seeder. Another nursery, specializing in small orders of native plants with a variety of seed types and sizes, would do better to sow everything by hand. The time interval in which the process must be accomplished is also significant. In evaluating the need for equipment, keep in mind how often and how fast the process must occur. If it will occur often, or there is a lot of it to do in a short time, it will pay to mechanize. However, if the process occurs only once or twice a year or it can be spread over considerable time, it may be more cost effective to keep the mechanization simple and hire more workers. This is particularly true in developing countries, where labor is relatively inexpensive and nurseries provide much-needed local employment.

### 1.4.5.1 Containers

**Types of containers.** Many different sizes and types of containers have been used in forest and conservation nurseries, and the choice will depend on the species of plant being grown, the type of nursery system, and the conditions on the outplanting site. Nurseries that grow their seedlings on contract will often have the container type controlled by the specifications of the contract, and some contract customers will even supply the containers. The choice of container type is one of the most critical in nursery development because it affects the design of the propagation area, type of benches, and the choice of handling and production equipment.

Although tree improvement seedlings and other specialty stock are often grown in large single containers (fig. 1.4.14C), the majority of forest and conservation plants are grown in aggregate containers known as **blocks, trays, or racks** (see fig. 1.3.21). The individual containers within the block are called **cells or cavities**. Besides being much smaller in volume than the typical container used to grow other ornamental or horticultural crops, many woody plants have aggressive root systems that will spiral in normal containers, especially at the bottom. Root spiraling greatly reduces seedling quality because it can cause instability after outplanting (fig. 1.4.19A). To solve this problem, special containers that are unique to the forest nursery industry have been designed with anti-spiraling ribs or are coated with root pruning chemicals (fig. 1.4.19B). (An estimate of typical container costs is provided in table 1.5.1 in chapter 5 of this volume. A comprehensive discussion on the biological and operational consideration in selecting a container is provided in volume two, pages 3-35.)



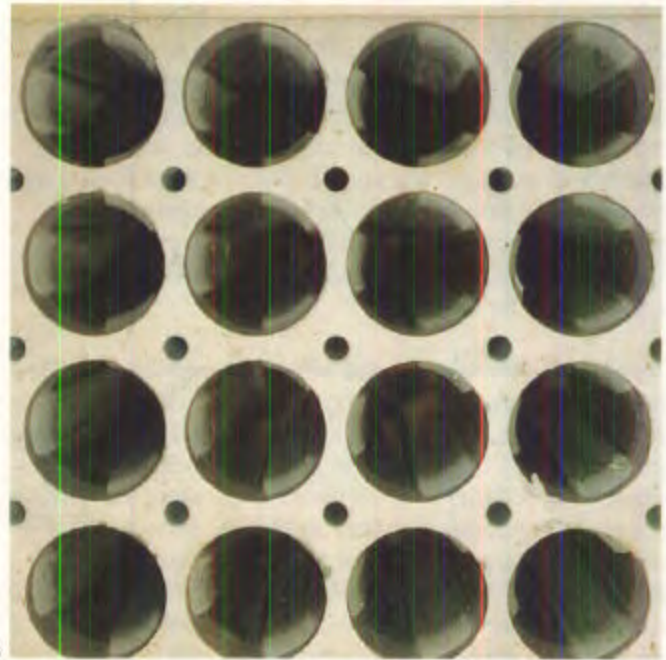

**Figure 1.4.19**—Many forest and conservation species have aggressive roots that spiral in smooth-walled containers and cause instability after outplanting (A). New specially designed containers feature vertical ribs to physically force roots to grow downwards and coatings that chemically prune roots as they grow (B).

**Cleaning and sterilizing used containers.** Although some nurseries use disposable paper or plastic bag containers, the majority are more durable and are designed to be reused (fig. 1.4.20A). Before doing so, however, the containers must be cleaned to remove cull seedlings and residual growing media, and they should also be sterilized to kill fungal pathogens, moss, algae, and liverworts. For small nurseries, the blocks are hand cleaned by shaking them upside down to remove loose material and then immersing them in a tub of disinfectant solution or hot water (fig. 1.4.20B). Larger nurseries have automated equipment called **block washers** that

use high-pressure water nozzles to clean the containers and steam or dip tanks to sterilize them (fig. 1.4.20C). Although commercial models are available, many nurseries have developed their own container cleaning systems, which typically use a section of conveyors to handle the containers as they move through the process. Considering cost and worker safety, steam and hot water can be just as effective as chemical sterilants (Peterson 1991). (Chemicals used to sterilize containers are discussed in volume five, pages 82-83.)



**Figure 1.4.20**—Most nurseries grow their seedlings in reusable containers, which must be stored (A), cleaned (B), and sterilized (C) before the next crop.



### 1.4.5.2 Artificial growing media

Although native soil is still used in some developing countries, the "soil" used in modern container nurseries is actually an artificial medium that is a blend of organic and inorganic components. (An example of typical growing medium costs is provided in table 1.1.5. A detailed discussion of growing media can be found in volume two, pages 43-81.)

**Components.** Most forest and conservation nurseries in the United States and Canada use an approximate 1 :1 mixture of vermiculite and sphagnum peat moss. Perlite can be added to increase porosity, and nurseries where peat moss is prohibitively expensive are using pine bark and other organic composts. A wide variety of premixed growing media can be purchased commercially in bulk or in loosely filled bags (fig. 1.4.21A). Several suppliers offer custom mixing to the grower's specifications and this option should be carefully evaluated before any mixing equipment is purchased. Slow-release fertilizer and other amendments are frequently added to many brands of premixed growing media. Some of these amendments, such as dolomitic limestone, can cause growth problems with some species. Therefore, growers should always specify that their media be prepared without amendments unless they are specifically requested.

Both vermiculite and sphagnum peat moss can be purchased in bulk, which is less expensive, and stored until they are needed. Vermiculite comes loose in plastic bags, but peat comes in compacted plastic-wrapped bales (fig. 1.4.21 B). Because plastic breaks down rapidly in sunlight, the bags should be stored inside or under plastic or canvas tarpaulins outside. Although commercial media are considered to be sterile, there have been problems with some sources of peat moss in recent years, and so many growers are requesting steam pasteurization of their media (fig. 1.4.21 C). Properly held, growing media or their components can be stored for many years without any loss in quality. Many nurseries, however, prefer mixing their own growing media not only because it can be less expensive but also because it allows precise control over composition and quality.

**Mixing growing media.** The object of this procedure is to thoroughly mix the components without destroying the physical structure of the peat and vermiculite. Both peat moss and vermiculite are fragile. Overmixing reduces porosity, which can lead to seedling growth problems and potential root disease. Small nurseries mix the components by hand on the floor or in a tank. The mixed material is usually shoveled onto a conveyor or auger that moves it to a hopper or bin that supplies a potting table or container filling equipment. Growers who handle their media properly will achieve adequate mixing, and consider the labor to be cheaper than the purchase of mixing equipment. Hand mixing introduces more variation into the operation, however. Variation in the uniformity of the growing medium and in the compaction within the container are the cause of many problems later in the growing season, because they affect both water and mineral nutrient availability.

Several types of mixing equipment are commercially available and, when properly used, can produce more-uniform growing media. Cement mixers can be used to mix small batches of media (fig. 1.4.22A), but they must be closely monitored so that mixing is uniform but the structure of the particles is not broken down. Larger nurseries can justify the expense of a **batch mixer** that use paddles and augers to mix 0.75 to 3.00 m<sup>3</sup> (1 to 4 yd<sup>3</sup>) of growing medium at one time (fig. 1.4.22B). More specialized and expensive **continuous mixing equipment** is designed to deliver the growing medium to a container filling and sowing line at rates as high as 38 m<sup>3</sup>/h (50 yd<sup>3</sup>/h). Continuous equipment uses ribbon mixers that meter growing media components from separate bins and incorporate them in the desired proportions (fig. 1.4.22C). These specialized mixers are also designed to blend incorporated fertilizers and other amendments at precise rates (Gleason 1986). Nurseries normally use this equipment to bulk-mix large volumes of growing medium and store it until needed. None of these mixers is foolproof, however, and so proper operation and monitoring are important in achieving a uniform, high-quality growing medium.



A

B

C

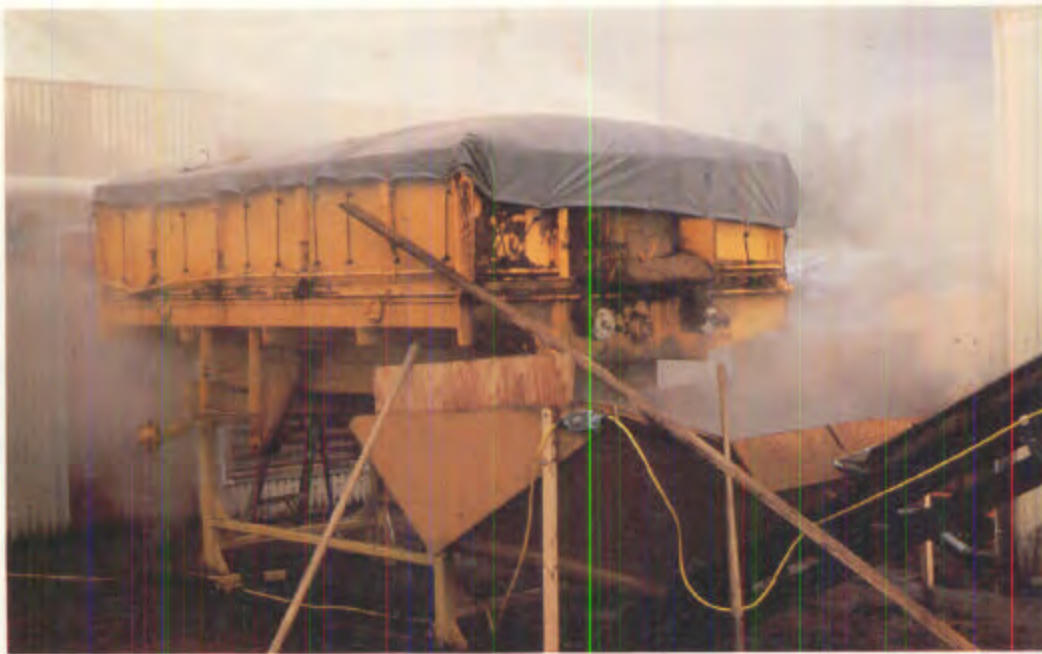

**Figure 1.4.21**—Artificial growing medium is typically composed of sphagnum peat moss and vermiculite and is available in premixed bags ready for filling the containers (A). Some nurseries buy bulk supplies of components (B) and mix their own medium. Vermiculite and perlite are sterile but peat moss should be treated with steam (C) or chemical fumigants before use.



**Figure 1.4.22**—Small quantities of growing medium can be mixed by hand or in cement mixers (A), but larger nurseries use batch mixers to keep the filling and sowing line supplied with medium (B). Continuous mixing equipment is designed to ensure even mixing and distribute incorporated materials without breaking down the physical structure of the components (C). (C, courtesy of J. Reid, Inno-Tec, Thunder Bay, ON.)

### 1.4.5.3 Sowing lines

Sowing is one of the most critical operations in container nursery culture, and also one of the most labor intensive. Therefore, many nurseries use a variety of equipment to improve the quality of the various tasks in the sowing process, while minimizing slow and expensive hand labor. Some nurseries assemble a sequence of different types of equipment into a **sowing line**. The process typically consists of four sequential operations:

1. Filling the containers (fig. 1.4.23A)
2. Tamping or dibbling the medium (fig. 1.4.23B)
3. Sowing the seed (fig. 1.4.23C)
4. Covering the seed with mulch (fig. 1.4.23D)



A



B

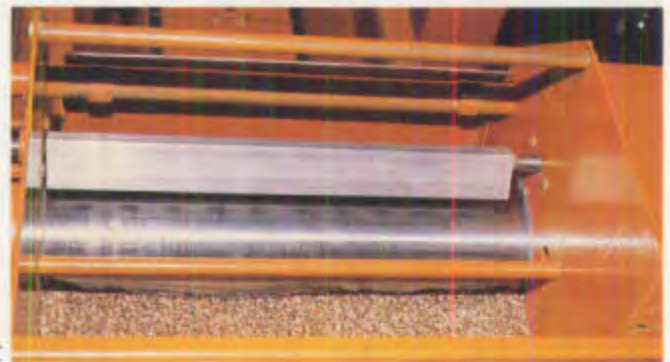

C

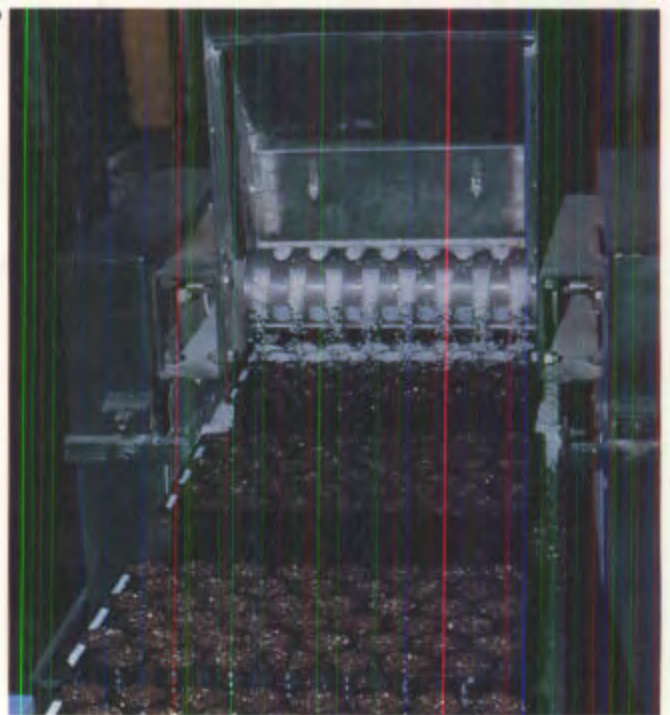

D

**Figure 1.4.23**—A sowing line consists of a series of sequential operations, which can be mechanized to increase their quality and speed: filling the containers (A), dibbling the medium (B), sowing the seed (C), and covering it with mulch (D).



**Figure 1.4.23 (continued)**— Although some nurseries assemble a sowing line out of different equipment, several brands of automated sowing lines can be purchased to do the entire process (E).

The equipment used in each of these operations is discussed in the following sections. Several manufacturers have developed mechanically sophisticated automated sowing equipment that combines the entire sowing line into one sequential process. The components of the different automated sowing lines vary between manufacturers, but all consist of a series of machines assembled in proper sequence and are typically connected with conveyors (fig. 1.4.23E). The main advantage of automated sowing equipment is convenience—the entire process is contained in one package that can be serviced by the same company. Most offer exchangeable components like the vacuum sowing drum to adjust for different containers and seeds. Automated sowing lines are relatively expensive, however, and have the disadvantage that one component may not perform as well as the others. Nurseries that build their own sowing lines can use different types of equipment and change them if a new type of equipment becomes available.

#### 1.4.5.4 Container filling equipment

In small to medium-sized nurseries, containers can be loaded with growing medium with very simple equip

ment, but in larger nurseries, mechanization becomes necessary to save labor and time. A large variety of potting machines and flat fillers are commercially available (Roskens 1993).

Container filling consists of two simultaneous operations: filling the containers with growing medium, and compacting it uniformly. Containers can be filled by hand, but this introduces undesirable variation into the operation and is relatively slow. Many nurseries use a homemade filler that consists of a hopper to store the growing medium and a filling surface where the medium is compacted into the containers (fig. 1.4.24A). The growing medium flows out of a gate in the hopper and is then spread manually across the top of the container block and into the cells. Some filling machines have an eccentric camshaft underneath that is driven by an electrical motor. This machine alternatively raises and drops the container block, increasing the uniformity of compaction and greatly speeding-up the filling process. Several commercial fillers are available that can accommodate forestry containers (fig. 1.4.24B). These consist of a hopper to hold the mix and an integral conveyor to move the mix to where it is sprinkled over the top of the container block, which moves by on another conveyor

while being shaken with a motorized vibrator. Surplus growing medium drops into a bin so that it can be recycled to the hopper.

After the containers have been filled, the surface of the growing medium must be shaped or compacted to make space for the seed—a process known as **tamping** or **dibbling**. Handmade dibbles can be made of wood or plastic and consist of a plate with plugs conforming to the diameter of the cavities with a length equal to the depth of the depression desired. When the plates are pressed onto the top of the containers, the plugs compact and shape the medium in each cavity (fig. 1.4.24C). One automated dibbler uses a pneumatic press with dibbles that have a convex or conical tip to create a conical depression, which forces the seed to roll to the center of the cavity (fig. 1.4.24D). Some automatic sowing lines feature a rotary drum with dibbles positioned to conform to the spacing of the cavities in the container (fig. 1.4.23B).

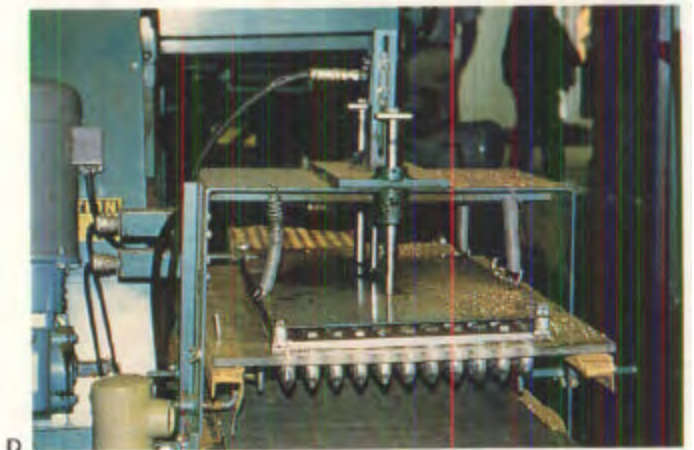

**Figure 1.4.24**—Homemade container filling equipment uses a vibrating or shaking motion to eliminate air pockets (A); more sophisticated commercial models offer recycling of media and other features (B). Filled containers are dibbled to compact the media and produce a space for the seed, either by hand (C) or as part of the mechanical sowing line (D).



### 1.-4.5.5 Sowing equipment

Hand seeding, although possible with all species of forest and conservation plants, is generally considered to be too slow to be cost effective where labor costs are high. Most conifer and many broadleaf seeds can be sown mechanically with good precision as long as seed quality is high, whereas very small, very large, or irregularly shaped seeds are normally hand sown. Container nursery operations require clean, high-quality tree seed of known germination capability. Clean seed simplifies sowing and increases its speed and accuracy because all seeders work better with clean seed. High-germination seed (greater than 85%) permits sowing fewer seeds per cavity, which reduces sowing and thinning costs. (See chapter 2 in volume six for specific information on seed quality and sowing.)

**Shutterbox seeders.** The simplest and least expensive seeder is the shutterbox, a rectangular box with a seed reservoir at one end and a seeding frame at the other (fig. 1.4.25A). The seeding frame corresponds to the outside dimensions of the container block or tray and contains a bottom plate with a grid of holes that correspond to the pattern of cavities in the container. This means that a shutterbox is custom built for a specific type of container and if different container types need to be sown, then a shutterbox will have to be constructed for each. The top layer of the seeding frame is a shutter with holes of the same pattern as the bottom plate, but offset to the side (fig. 1.4.25B). The holes in the shutter are drilled just large enough to hold the number of seeds to be sown, usually 2 to 6. Different shutters are needed to sow a different number of seeds per cavity or for another type of seed.

To operate the shutterbox, the operator hand-sweeps seed from the reservoir onto the shutter, making certain that each hole is filled (fig. 1.4.25C). Excess seed is swept back into the reservoir. When the shutter is moved laterally so that its holes are aligned with those in the bottom plate, the seeds drop into the container (fig. 1.4.25D). Operation of a shutterbox requires practice, but experienced workers can achieve acceptable seeding rates with this simple device. Shutterboxes can be custom-made of wood, metal, or plastic, and are also available commercially. They work best with roughly spherical seeds like those of pine species, and will jam if seeds are dirty.

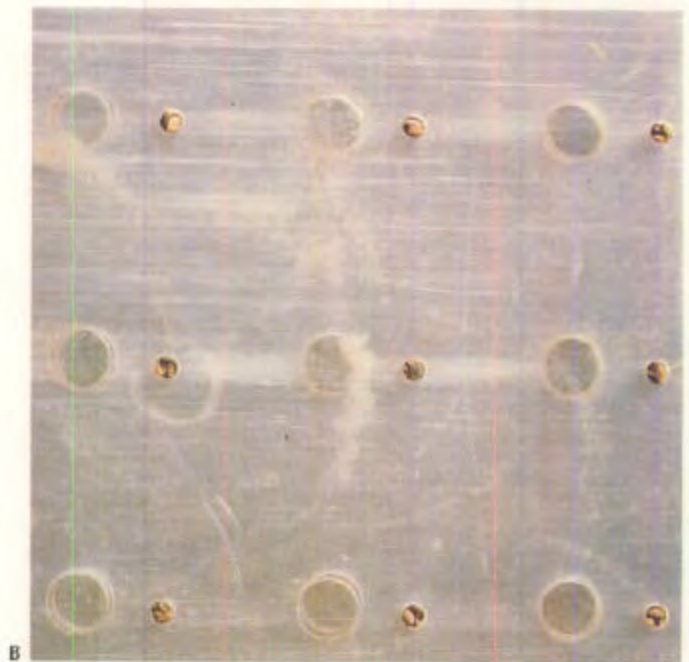

**Figure 1.4.25—**Shutterbox seeders offer a simple but effective way to increase sowing speed and efficiency. They are custom-made to fit each type of container (A) with precisely spaced holes in the shutter (B) that ensure that the desired number of seeds is dropped into each cell as the shutter is moved laterally (C & D).

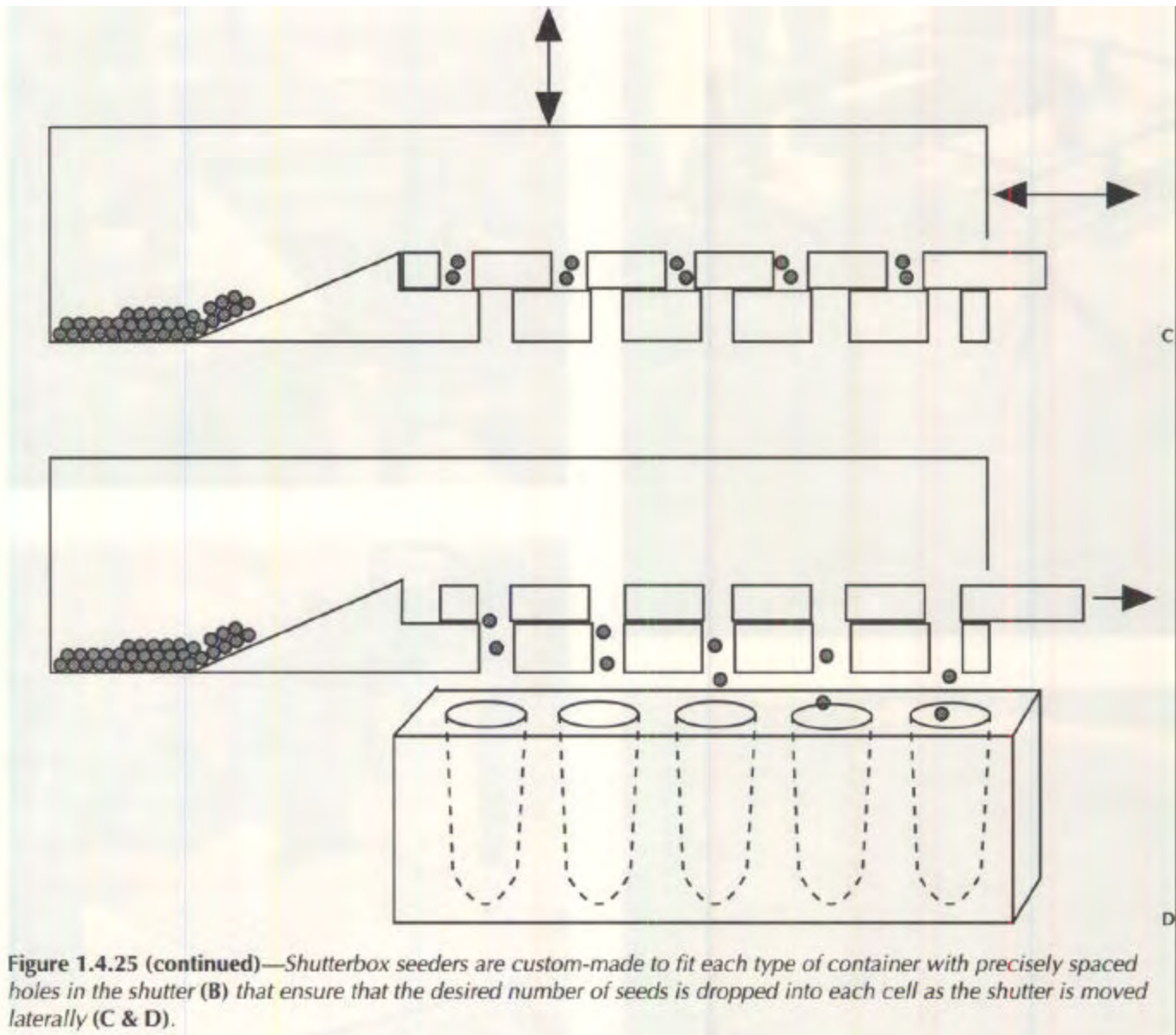

**Figure 1.4.25 (continued)**—Shutterbox seeders are custom-made to fit each type of container with precisely spaced holes in the shutter (B) that ensure that the desired number of seeds is dropped into each cell as the shutter is moved laterally (C & D).

**Vacuum plate seeders.** The vacuum plate seeder consists of a hollow frame that is connected to a shop vacuum cleaner (fig. 1.4.26A). The frame is the same size as the container block and has a grid pattern of holes over the bottom surface corresponding to the positions of cavities in the container blocks. The number of holes at each position determines the number of seeds per cavity. When the hollow frame is held over the seed tray and a vacuum is applied, seeds are held on the bottom plate (fig. 1.4.26B). The frame is then

aligned over the container block and the vacuum is broken, allowing the seeds to fall into the container cavities (fig. 1.4.26C). Vacuum plate seeders can be homemade, and manufactured ones are relatively inexpensive.

Shutterbox and vacuum plate seeders are ideal for small to medium-sized nurseries because they require low initial capital investment and are surprisingly productive. Both are reasonably precise in sowing the desired



**Figure 1.4.26**—Vacuum plate seeders (A) pick up seeds and hold them on the hollow head in the same grid pattern as the cells in the container. The number of holes determines the sowing density (B). When the vacuum is released, the entire container is sown at once (C). Both shutterboxes and vacuum plate seeders require monitoring and often extra seeds need to be sown in blank containers (D).

number of seeds per cavity, but most nurseries use hand sowing to correct deficiencies (fig. 1.4.26D). Actual production figures vary considerably based on differ-

ences in sowing lines, labor, seed quality, and supervision. However, the potential production is 300,000 to 500,000 cavities per machine per day.

**Automated and precision seeders.** The next level of container seeders are more mechanically sophisticated and expensive but are very efficient at delivering exact numbers of seed to each cavity (Reid 1994). Several models of automated seeders can be purchased that use a variety of seed delivery techniques, and sowing precisions of greater than 90% are possible. Vacuum drum seeders feature a hollow drum that picks up seeds from a hopper and drops them, one row at a time, when a container passed underneath on a conveyor belt (fig. 1.4.23C). Some automated seeders hold one or two seeds at a time on a vacuum nozzle and then distribute them through drop tubes to the containers (fig. 1.4.27A). Most can accommodate different types of containers with slight modifications, but vibratory feeders can handle different sizes or shapes of seed better than the vacuum models. Vacuum seeders are generally faster, however.

The most sophisticated type of seeding equipment are precision seeders that are specifically designed to place one seed per cavity, thus eliminating the need for thinning or transplanting (Reid 1994). Sowing efficiencies can be as high as 98% (fig. 1.4.27B). Some models pick up single seeds with needle-point vacuum heads (fig. 1.4.27C), others use vibrating feeders to isolate single seed (**singulation**) and electric eyes to control the seeding rate, whereas yet others use vibratory singulation and pocket drop distribution systems (fig. 1.4.27D). Precision seeders should only be used with the highest quality seed: well cleaned, uniform in size, and of very high germination rate. The production capabilities of the various models vary widely, but all are relatively expensive. Precision seeders can usually be justified in larger nurseries with efficient sowing lines. Precision seeding technology is still developing and so, before deciding to purchase a precision seeder, nursery developers should talk to other nurseries to learn how they function under operational conditions.

The ultimate in precision seeding is to place a pregerminated seed in each container, assuring nearly 100% cell occupancy and eliminating costly blanks or thinning costs. Research into pregermination protocols and experiments in liquid or gel sowing are continuing, and equipment has already been perfected for some horticultural crops. The problem with most forest and conservation species is that seed quality is extremely variable due to the difficulty of cleaning and processing the seed as well as complex seed dormancy. Nurseries growing large seedlots of species with uniformly clean, high-germination seed may find use for this new equipment, however.

**Seed mulching (gritting).** After the containers are seeded, the seed is covered with a thin layer of sand, grit, vermiculite, perlite, or some other mulching material. Seed mulches physically hold the seed in place and prohibit excessive growth of algae, moss, or liverworts, which can delay or completely inhibit seed germination (fig. 1.4.28A). White materials like perlite or poultry grit are recommended because they reflect sunlight to keep the seed cool and moist (fig. 1.4.28B). The objective of seed mulching is to apply the mulch evenly over the top of the container block to the depth desired. Mulches that are too thin will allow the seed to dry out, whereas those that are too thick may inhibit seed germination. Irregularly applied mulch may be worse than none at all because it will cause uneven germination rates and complicate later cultural practices (fig. 1.4.28C). Mulching is sometimes done by hand, but more often by simple machinery that is often homemade (fig. 1.4.28D). Automated seeding lines accurately meter out the mulch into each container as it passes underneath on a conveyor (fig. 1.4.23D).

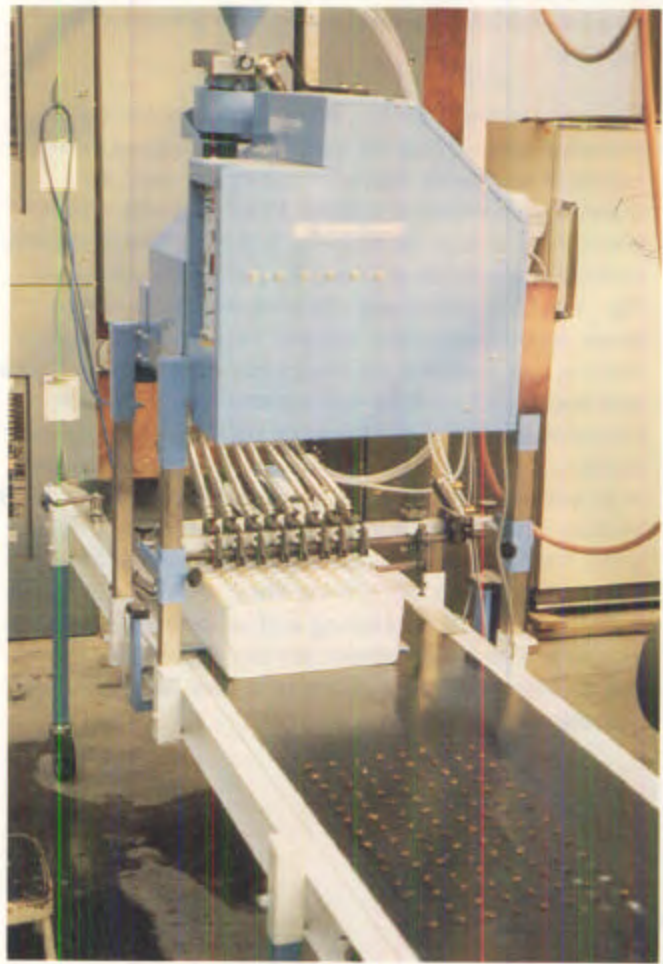
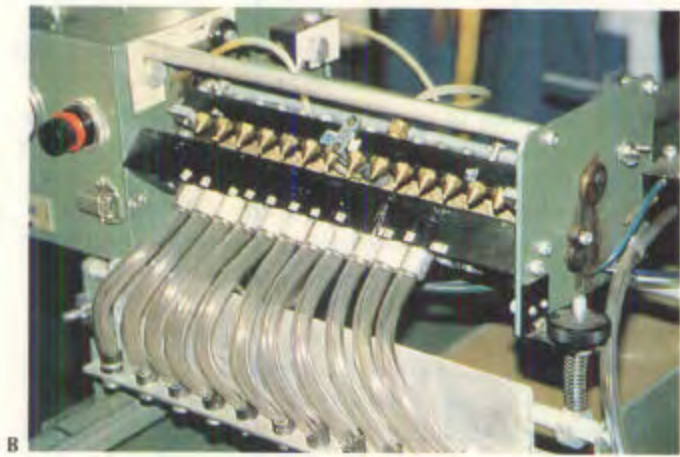
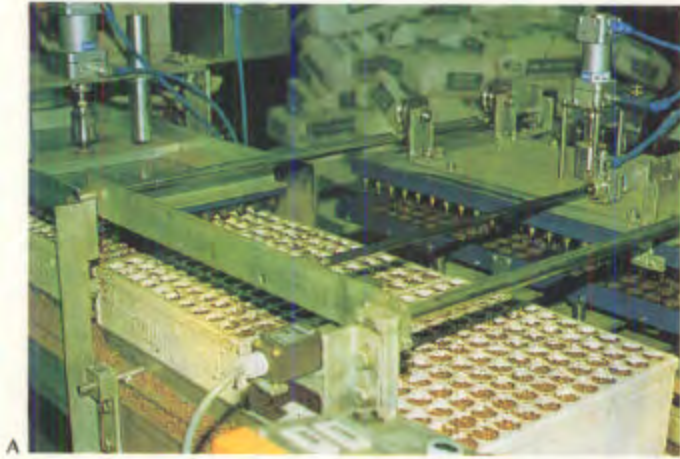

**Figure 1.4.27**—Automated and precision seeders offer excellent control of sowing density. Vacuum models hold seeds on a rotating drum or hollow nozzles (A) and either drop them directly into the container or use a series of drop tubes (B) to ensure accurate placement (C). Other models feature vibratory feeders and electric eyes to precisely meter the seeds (D).

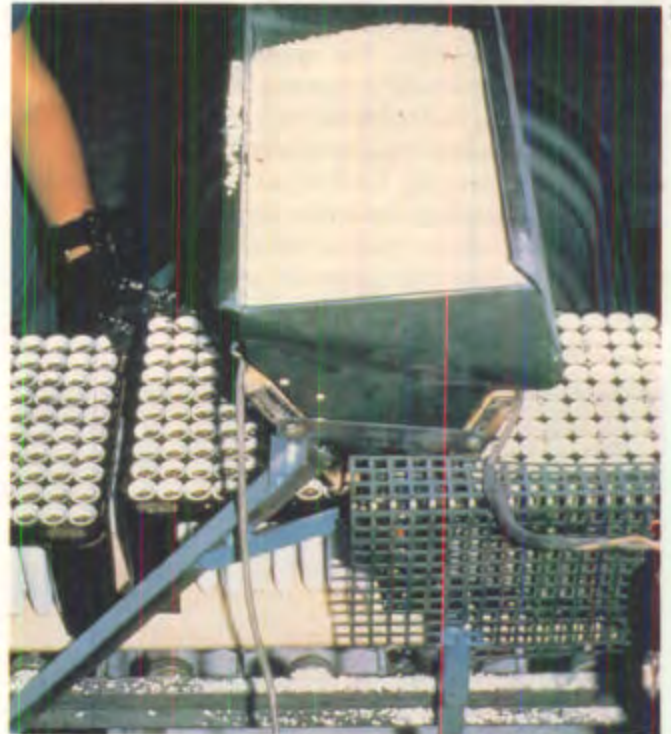
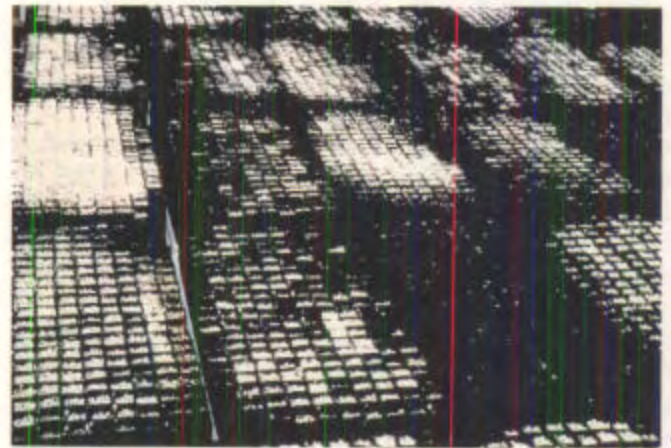

**Figure 1.4.28**—Seed mulches hold the sown seed in place and reduce the growth of algae, moss, and liverworts (A). White materials such as perlite or grit (B) are recommended because they reflect sunlight and reduce the chance of heat injury. Uneven application results in variable germination (C), and so most nurseries use mulching equipment to ensure even coverage (D).

### 1.4.5.6 Transplanting equipment

At the present time, transplanting seedlings from one container to another is not common in forest and conservation nurseries. However, some nurseries hand transplant extra seedlings to fill empty cells during the germination stage, especially when seed is in short supply. In the last several years, several types of mechanical transplanters have been developed to transplant miniature plugs of flowers and vegetables into other larger containers (Onofrey 1993). There is also a need for transplanting equipment for tree seedlings because production space in greenhouses is expensive and the cost of hand transplanting is prohibitive. One automatic transplanter in the development stage transplants miniature seedling plugs grown under intensive culture into larger containers that can be raised under extensive culture (Hodgson 1993). The seedlings are grown for a few weeks in Miniblock® containers with a special growing medium that holds the root plug together. The transplanting process consists of predibbling the larger capacity containers (fig. 1.4.29A) and then mechanically pushing the miniplugs down into the cavities (fig. 1.4.29B). Operational trials of this new propagation technology are currently underway and initial results look promising.



### 1.4.5.7 Pesticide application equipment

In spite of a grower's best efforts at prevention, it will occasionally be necessary to use pesticides to protect the crop. In container tree nurseries, pesticides are typically applied as seed treatments, liquid sprays and drenches, baits, and aerosols. The best application method will depend on several factors: the type of pesticide, legal restrictions, characteristics of the target pest, sensitivity of the crop, environmental conditions, and type of equipment.

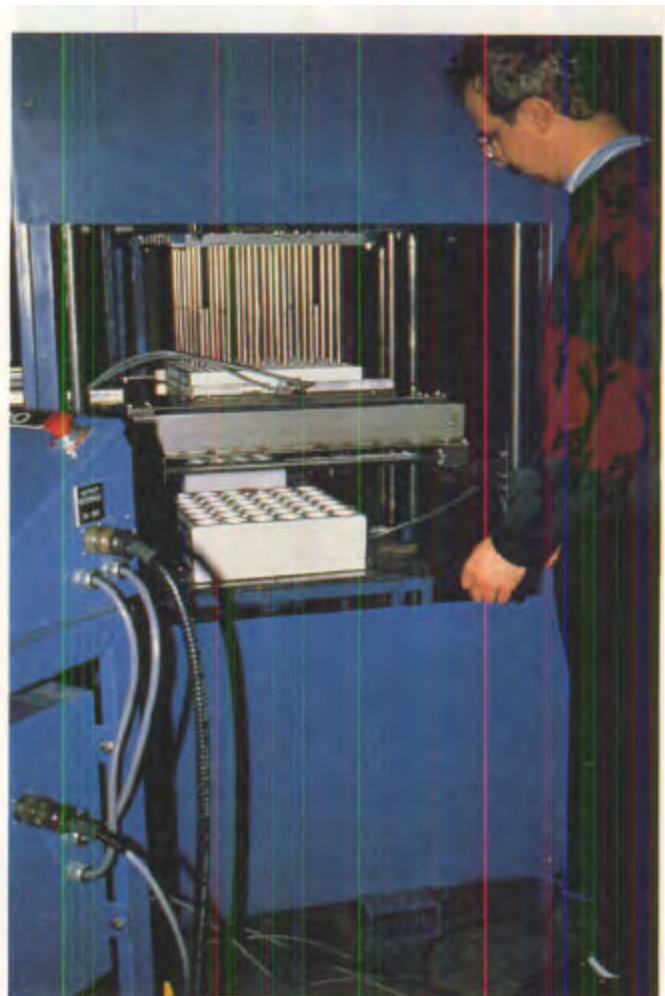

**Figure 1.4.29**—Transplanting young seedlings from miniature containers into larger containers is a new technology that shows promise. The large containers are predibbled (A) and then the miniature seedlings are transplanted downward into the cavity (B). (Courtesy of Beaver Plastics Ltd., Edmonton, AB.)

The majority of pesticides are applied as sprays, however. Foliar sprays are used for exposed insects and pathogens, and drenches for root problems. Both techniques require mixing the pesticide with water and applying it to the problem area with portable sprayers or injecting it through the irrigation system. Foliar sprays require moderate- to high-pressure nozzles to ensure even coverage of the seedling shoot, and hollow- or solid-cone nozzles are recommended. Drenches require lower pressure flooding nozzles that allow the pesticide to infiltrate the growing medium completely. The pesticide formulation will also affect the type of spray equipment because some materials, such as wettable powders, require agitation. Bohmont (1983) is an excellent source of information on all aspects of pesticide use. (See volume five, pages 76-93 for specific information on pest management strategies, and pesticide application, handling, and storage.)

**Portable sprayers.** Growers should constantly monitor their crops so that pest and disease problems can be detected when the problem is still confined to small scattered areas. Then, these areas can be spot treated with portable sprayers (fig. 1.4.30A). Portable sprayers come in all sizes, and the choice will depend on the amount of pesticide that needs to be applied. Growers should never mix more chemical than can be used in one application, making hand sprayers ideal for small jobs, but higher capacity equipment is needed for more extensive spraying (fig. 1.4.30B).

New technology is revolutionizing pesticide application. Although they are more expensive, low-volume sprayers are rapidly replacing traditional hydraulic sprayers for nursery applications (Bartok 1992). Whereas traditional sprayers use large volumes of diluted pesticides, low-volume sprayers use relatively small quantities of concentrate. They save time and money because they cover the crop more evenly and quickly, and because they use a concentrate, the labor and potential hazards of mixing are eliminated.

Electrostatic sprayers are particularly attractive for container nursery use because the small portable models that are currently available can be used safely at close distances (fig. 1.4.30C). These sprayers produce very small positively charged droplets that disperse well because they repel each other. Coverage is excellent because the droplets are attracted to the negatively charged plant, and so can reach even the bottoms of leaves. Air-assisted electrostatic sprayers are more effective than gravity or mechanical types (Lindquist and Powell 1991).

**Boom sprayers.** When larger areas require treatment, boom sprayers are the most efficient way to apply pesticides. Nurseries with fertilizer injection equipment can also inject pesticides and other chemicals directly into the irrigation system. Both foliar sprays and drenches can be applied, depending on the nozzle used and the length of time of application. This technique is also safer because the operator does not have to be in the greenhouse while the application is in progress. Although fixed sprinkler systems can also be used, their poorer coverage means more pesticide will be wasted and there will be more runoff (Dumroese and others 1992). Pesticides can be applied to open growing compounds with mobile spray booms (fig. 1.4.30D).

Possible water pollution from agricultural pesticides is an increasing concern and so anyone purchasing pesticide application equipment should consider pollution potential in addition to cost and efficiency.





A



B



C



D

**Figure 1.4.30**—Liquid pesticides are applied with hand sprayers (A) or larger capacity portable spray equipment (B). New low-volume equipment such as the electrostatic sprayer (C) uses less pesticide and provides better coverage. Tractor-drawn boom sprayers can be used to apply pesticides or liquid fertilizers to outdoor growing areas (D).

## 1.4.6 Seedling Harvesting Equipment

The next step in the seedling production cycle involves moving seedlings to an area where they can be graded and packed for storage (fig. 1.4.11). Some nurseries do this in the aisles of the propagation area, whereas others move the seedlings to the headhouse or other work area. The way in which the seedlings will be delivered to the outplanting site determines what type of harvesting and storage system will be needed. There are two options: shipping the seedlings in their growth containers, or removing them and shipping them in boxes. Nurseries that choose the former store their seedlings in sheltered storage and use specially equipped trucks to deliver them to the outplanting site. Sophisticated equipment has been developed to handle the seedlings at the nursery and load them onto the delivery trucks (fig. 1.4.16A&B). When seedlings are shipped in their containers, storage racks must be designed to protect the seedlings and prevent them from being crushed (fig. 1.4.31A).

Not every container cavity yields a usable seedling, however, and the process of eliminating plants that are too small or that have other obvious defects is called **grading** or **culling**. The main advantage of culling is that the volume and weight of storing and shipping the seedlings are lessened, and planting will be more efficient. Nurseries that can produce a high percentage of shippable seedlings can avoid the extra cost of grading. Most seedling users expect that only plantable seedlings will be shipped, and so nurseries assemble grading and packing lines to process seedlings for storage and shipping.

**Figure 1.4.31**—Seedlings that are shipped to the outplanting site in their containers are boxed or stored on racks (A), so that they are protected during transport. Many nurseries process their seedlings in a packing line where the seedlings are pulled from the container, then graded, bundled, and boxed for storage and shipping (B).

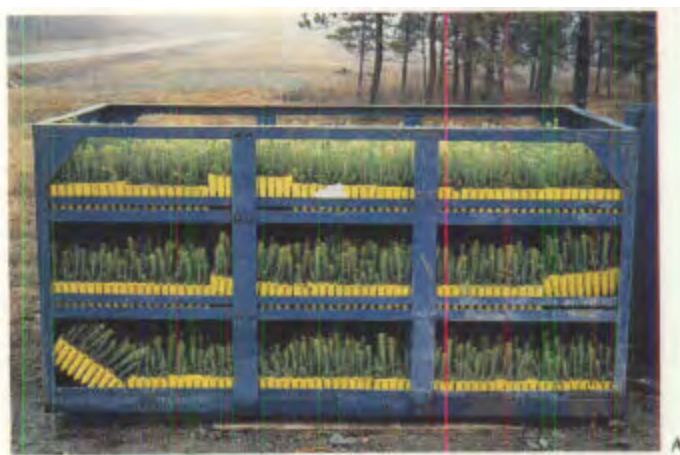

### 1.4.6.1 Grading and packing lines

The process of extracting seedlings from their containers, grading, and packaging them—commonly called **pulling and wrapping**—has become increasingly popular in recent years. This is a labor-intensive process, and so nurseries combine the sequence of tasks into grading and packing lines that are connected by conveyors (fig. 1.4.31 B). These can be rather simple set-ups in which all the steps are completed by hand, from pulling the seedlings and grading them, to wrapping them and placing them into storage boxes. Larger nurseries use a variety of equipment to speed up the process and make it more efficient.

In addition to reducing labor costs, the mechanization of grading and packing has become necessary because of

the high incidence of injuries to workers. Many forest and conservation seedlings have aggressive root systems and develop a firm plug by the end of the growing cycle. The roots of some species even grow into small holes in the walls of the container cavities, especially with Styrofoam blocks. This makes the seedlings difficult to remove from the containers, and nursery workers on the packing line often develop tendonitis and other chronic wrist and lower arm injuries. To make the seedlings easier to extract, many nurseries have developed custom equipment. Mechanical shakers use a jolting motion to loosen the seedling plugs from their containers (fig. 1.4.32A) as the first step in the packing line. This is followed by seedling extractors that physically push one row of seedlings at a time from the container and onto the grading belt (fig. 1.4.32B).



A C



B D

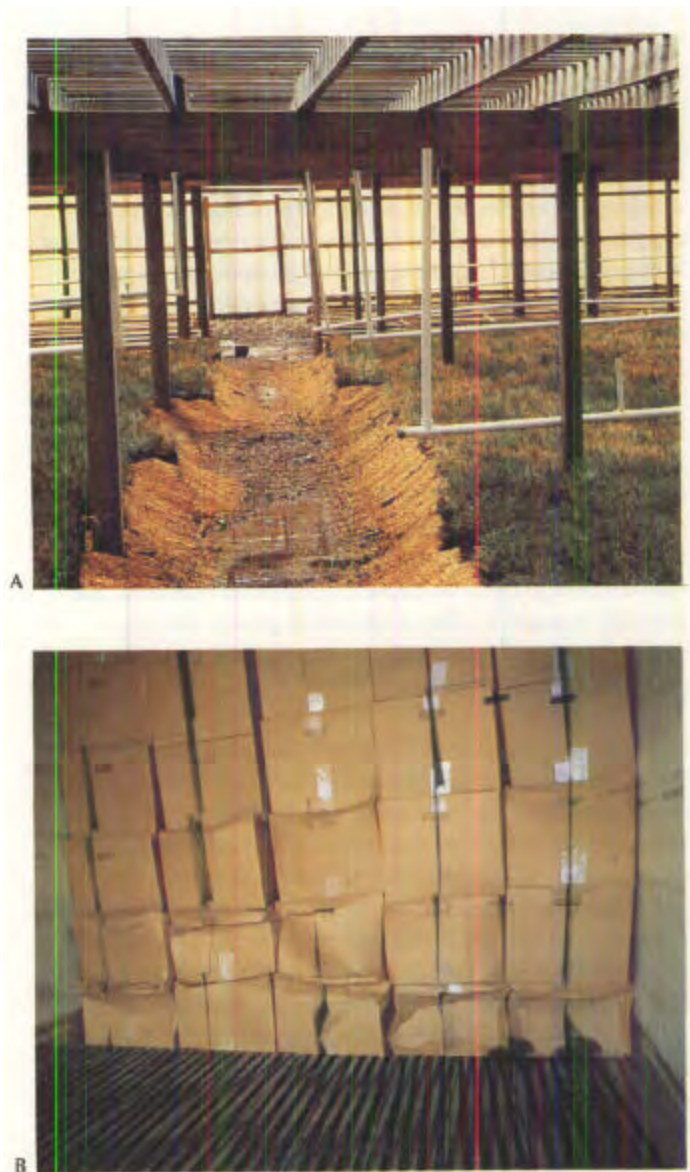

**Figure 1.4.32**—New equipment is being developed to make seedlings easier to pull from the container. Mechanical thumpers (A) loosen the seedlings with a jarring motion and then the seedlings can be pushed from the container onto the grading belt with an extractor (B). Graders count and bundle the seedlings into plastic bags (C) or bind the root plugs together with plastic wrap (D).

Once the workers have extracted the seedlings from the containers, they visually inspect them and place them on the grading belt in bunches of 5 to 25 seedlings. The next step is to bag or wrap the bunches of seedlings and place them into the storage boxes. Bagging machines (fig. 1.4.32C) hold a supply of plastic bags that are automatically inflated by a flow of air, making it easier to insert the seedlings. The bags are just deep enough to enclose the root plugs to retard desiccation, but keep the seedling shoot uncovered to reduce the chance for storage molds. Other nurseries use plastic film to wrap the root plugs of the seedlings into bundles before boxing (fig. 1.4.32D). The final step in the grading and packing process involves sealing the storage boxes, marking them with the species, seedlot, number of seedlings, and other important information. Then they are transported to storage until they can be shipped (fig. 1.4.11).

#### 1.4.6.2 Storage

After the seedlings have been transported to the storage areas, there is no need for any other equipment until they are shipped to the outplanting site. In sheltered storage, seedlings should be stored on the ground to protect the roots systems, which are much more susceptible to freezing than the tops. They should be bunched together to minimize the perimeter and their root systems insulated with sawdust or other material (fig. 1.4.33A). Seedlings in refrigerated storage must be stored on racks or tiered pallets to support their weight and avoid crushing (fig. 1.4.33B). The storage boxes should be lined with a thin plastic bag to retard moisture loss while still permitting oxygen exchange. Properly packaged seedlings do not require humidity control in the storage building. (Sheltered storage and refrigerated storage are discussed in section 1.3.5.4, and will be covered in detail in volume seven of this series.)



**Figure 1.4.33**—Seedlings that are overwintered in their containers must be protected against freezing temperatures and drying winds (A). Boxed seedlings must be placed on racks during storage and shipping to prevent damage (B).

## 1.4.7 Summary

Two general categories of equipment are used in container tree nurseries. A wide variety of equipment is used to modify the propagation environment to optimize the six factors limiting to seedling growth: temperature, humidity, light, carbon dioxide, water, and mineral nutrients. The degree of modification depends on the type of structure and the environment control equipment that is provided. Seedlings raised in open growing compounds can be supplied with irrigation and fertilization, and light and temperature can be controlled to a minor degree. Container nurseries that grow their seedlings in some sort of a propagation structure have the potential to control all the limiting factors. These factors can be controlled individually or, in fully controlled environments, sophisticated controls (including computers) balance all factors to produce conditions that are ideal for seedling propagation. Forest and conservation seedlings are a valuable crop and so nurseries use security systems to detect electrical power failure, mechanical problems with environmental control equipment, fire, or burglary.

The second category of container nursery equipment includes the materials and equipment needed to produce a crop of seedlings. Growing tree seedlings consists of a sequence of processes that begin when the seeds or cuttings are delivered to the nursery and ends when the seedlings are shipped to the outplanting site. Container crops can be grown directly on the floor, on pallets, racks, or benches, and the choice is critical from both a biological and operational standpoint. Biologically, tree seedlings must be supported so that their roots will air-prune, and operationally, containers must be positioned so that they make the most efficient use of the propagation area and can be easily handled and moved. The container support system must be compatible with the handling system, and nurseries use forklifts and conveyors to move seedlings and supplies.

To be most efficient and cost effective, seedling production equipment should be chosen so that it fits into an overall sequence. All the various steps in the process can be done by hand, and so the need for equipment is dependent on the size and complexity of the nursery as well as the available technology, finances, and labor. With some crops, equipment cannot be justified but, for others, would be strongly advised. In evaluating the need for equipment, nursery managers must keep in mind how often and how fast the operation must occur. If the process will occur frequently or must be done in a short time, it may pay to mechanize. Worker safety is also a consideration because many operations can lead to fatigue and injury and so the process should be mechanized if possible.

## 1.4.8 Literature Cited

- Aldrich, R.A.; Bartok, J.W., Jr. 1989. Greenhouse engineering. Bull. NRAES-33. Ithaca, NY: Cornell University, Northeast Regional Agricultural Engineering Service. 203 p.
- Acme. 1988. The greenhouse climate control handbook: engineering principles and design procedures. Muskogee, OK: Acme Engineering and Manufacturing Company. 23 p.
- Argus Control Systems. 1990. Argus Control System brochure, Sept. 19, 1990. White Rock, BC. 9 p.
- ASHRAE. 1989. ASHRAE Handbook: fundamentals. Atlanta: American Society of Heating, Refrigeration and Air Conditioning Engineers, Inc. 792 p.
- Ball, G.J. 1991. Ball Redbook, 15th ed. West Chicago, IL: George Ball Publishing. 802 p.
- Bartok, J.W., Jr. 1994. Don't overlook benefits of HAF. Greenhouse Manager 12(11):90-92.
- Bartok, J.W., Jr. 1993a. How to select the right fan and install it properly. Greenhouse Grower 11(4):20-21, 23.
- Bartok, J.W., Jr. 1993b. Computers may help you determine your ideal greenhouse environment. Greenhouse Manager 12(4):139.
- Bartok, J.W., Jr. 1992. Economics of low-volume sprayers threaten future of hydraulic systems. Greenhouse Manager 10(10):91.
- Bartok, J.W., Jr. 1991 a. Inexpensive and easy to maintain, there's a plastic pipe for every task. Greenhouse Manager 9(9):145-146.
- Bartok, J.W., Jr. 1991 b. Cut costs with conveyors. Greenhouse Grower 9(13):26, 28-29.
- Bartok, J.W., Jr. 1987. Alarm system provides inexpensive insurance. Greenhouse Manager 6(8):91-93.
- Bartok, J.W., Jr. 1986. Materials handling basics for greenhouse nursery operations. Publ. GMM-94. Storrs, CT: University of Connecticut, Cooperative Extension Service. 3 p.
- Bickford, E.D.; Dunn, S. 1972. Lighting for plant growth. Kent, OH: Kent State University Press. 221 p.
- Bohmert, B.L. 1983. The new pesticide user's guide. Reston, VA: Reston Publishing Co. 452 p.
- Charlton, A. 1992. Generators can meet your power and budget needs. The Digger 36(10):18.
- Chris Industries Corp. 1992. Personal communication. St. Petersburg, FL.
- Conway, B. 1987. Growing a greenhouse. Silviculture 2(2):18-19.
- Dumroese, R.K.; Page-Dumroese, D.S.; Wenny, D.L. 1992. Managing pesticide and fertilizer leaching and runoff in a container nursery. In: Landis, T.D., tech. coord. Proceedings, Intermountain Forest Nursery Association; 1991 August 12-16; Park City, UT. Gen. Tech. Rep. RM-211. Ft. Collins, CO: USDA Forest Service, Rocky Mountain Forest and Range Experiment Station: 27-33.
- Elston, R. 1991. A look at seeders. Greenhouse Manager 10(6):115-117.
- Gleason, G.S. 1986. Continuous mixing systems for growing media. Pap. 86-1096. In: Proceedings, Summer meeting of American Society of Agricultural Engineers. 1986 June 29-July 2; San Luis Obispo, CA. St. Joseph, MI: American Society of Agricultural Engineers. 11 p.
- Greenhouse Manager. 1994a. First step: electronic thermostats. Greenhouse Manager 12(11):64-67.
- Greenhouse Manager. 1994b. A look at: environmental computers. Greenhouse Manager 12(11):69-71.
- Greenhouse Manager. 1993a. A look at: boom irrigation. Greenhouse Manager 11(10):80-81.
- Greenhouse Manager. 1993b. A look at: metal benches and bench tops. Greenhouse Manager 12(6): 58-60.
- Hicklenton, P.R. 1988. CO<sub>2</sub> enrichment in the greenhouse: principles and practice. Portland, OR: Timber Press. 58 p.
- Hodgson, T.J. 1993. Personal communication. Edmonton, AB: Beaver Plastics, Ltd.
- Hummert, P. 1993. Personal communication. St. Louis, MO: Hummert International.
- Labbate, E. 1994. Personal communication. Leamington, ON: Climate Control Systems.
- Langhans, R.W. 1980. Greenhouse management. Ithaca, NY: Halcyon Press. 270 p.
- Lindquist, R.K.; Powell, C.C. 1991. Pesticide application alternatives. Greenhouse Manager 9(12):62, 64.
- Mackenzie, A.J.G. 1993. Personal communication. White Rock, BC: Argus Control Systems, Ltd.
- McConkey, J.M. 1993. Personal communication. Sumner, WA: J.M. McConkey, Co.
- Melby, P. 1988. Simplified irrigation design. Mesa, AZ: PDA Publishers. 190 p.
- Nelson, P.V. 1991. Greenhouse operation and management, 4th ed. Englewood Cliffs, NJ: Prentice Hall. 612 p.
- Onofrey, D. 1993. Today's transplanters. Greenhouse Grower 11(11):70-74.
- Pair, C.H.; Hinz, W.H.; Frost, K.R.; Sneed, R.E.; Schiltz, T.J. 1983. Irrigation. Arlington, VA: The Irrigation Association. 686 p.
- Peterson, M. 1991. Guidelines for the sanitation of nursery seedling containers. Supplement to FRDA 140. Victoria, BC: Ministry of Forests, Silviculture Branch. 16 p.

- Reid, J.I. 1994. Personal communication. Thunder Bay, ON:  
InnoTec, Inc.
- Roberts, W.J.; Giacomelli, G. 1992. Designs on ventilation.  
Greenhouse Grower 10(4):20,22,24,25.
- Roskins, L. 1993. A look at: flat fillers, potting units.  
Greenhouse Manager 12(8):91-94.
- Speedling, Inc. 1993. Personal communication. Sun City, FL:  
Speedling, Inc.
- Sorvig, K. 1993. Trading wood for plastic. American  
Nurseryman 177(11): 58-63.
- Whitesides, R. 1993. Ways to make watering systems more  
precise. Greenhouse Manager 11(10):42-44.
- Whitesides, R. 1991. Computers are a cost-effective way to  
maintain your competitive edge. Greenhouse Manager  
10(2):56-58, 60, 62, 64.